

CS425

Computer Systems Architecture

Fall 2019

Introduction

Outline

- Logistics
- CPU Evolution
- Course goal (what is Computer Architecture?)

Course Information

- Elective course in Hardware and Computer Systems (E4)
 - 6 ECTS
 - **Prerequisite:** CS225 Computer Organization
- **Instructors:**
 - Dr. Vassilis Papaefstathiou (papaef@ics.forth.gr)
 - Prof. Manolis Katevenis (kateveni@ics.forth.gr)
- **Teaching Assistants:**
 - Mr. Sotiris Totomis (sototo@csd.uoc.gr)
 - Mr. Iasonas Mastorakis (imast@csd.uoc.gr)
- **Lectures:**
 - Monday 16:15 – 18:00 (H.206)
 - Wednesday 16:15 – 18:00 (H.206)
 - Friday 16:15 – 18:00 (H.206) backup slot when needed

Grading

- **Homeworks & Programming Assignments: 35%**
 - Mandatory
 - Average Grade > 4.5
- **Midterm Exam: 20% (mandatory)**
- **Final Exam: 45% (grade > 4.5)**

Course Material

- **Website:**

- <http://www.csd.uoc.gr/~hy425>

- **Mailing List:**

- hy425-list@csd.uoc.gr (subscribe with majordomo)

- **Textbook:**

- Hennessy and Patterson, Computer Architecture, A Quantitative Approach. 3rd Edition Available in Greek (Tziolas publishers, translation by D. Pnevmatikatos, D. Serpanos and G. Stamoulis). ISBN 97896041807693

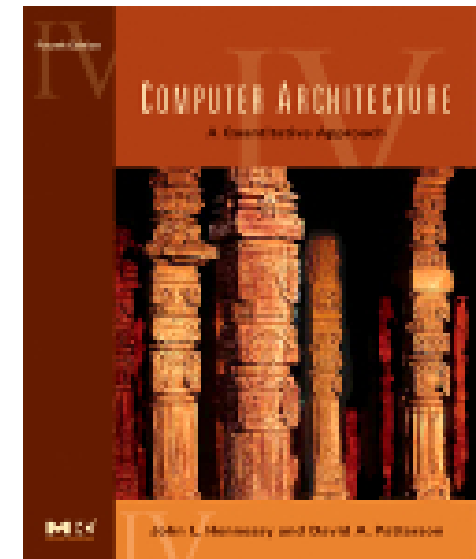

Tentative Schedule

- Fundamentals, metrics, pipelining (1.5 weeks)
- Instruction Level Parallelism (2 weeks)
- Branch prediction (1 week)
- Multiple issue, VLIW, vector, multithreading (2 weeks)
- Memory hierarchy, caches and optimizations (2.5 weeks)
- Multicore processors, cache coherence (2 weeks)
- Main memory technologies (1 week)
- Advanced topics (1 week)

History in Computer Devices

- EDSAC, University of Cambridge, UK, 1949-1958 (mercury-based memory, logic, punched tape, teleprinter, EDSAC2 1965)

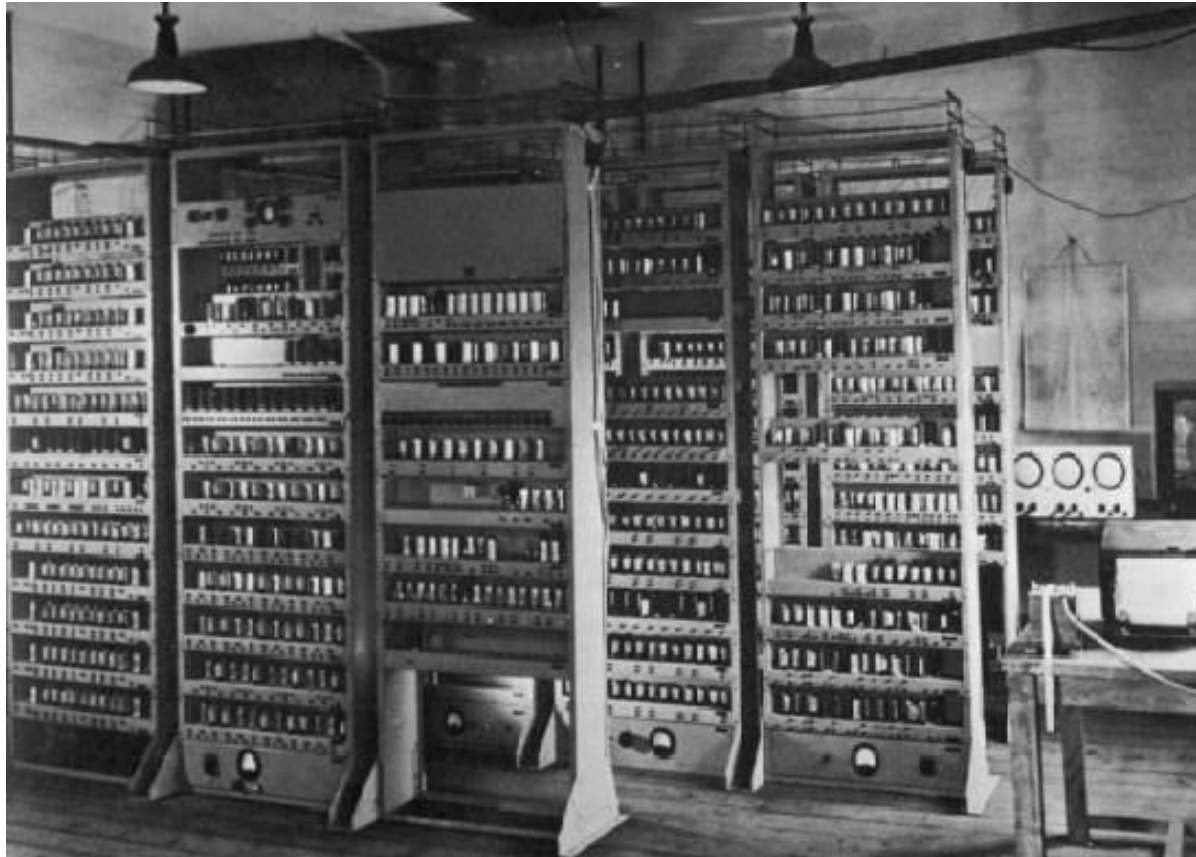

Computing Systems Today

- The world is a large parallel system
 - Microprocessors everywhere
 - Vast infrastructure behind them



'70: microproc. & supercomputers
'80: compilers, OS, RISC, x86
'90: Internet, WWW, PDA
'00: mobile, cell phones, embedded cpus
'10: internet of things (IoT)

Improvement in Computer

- Radical progress in computers due to:
 - Technological improvements (next few slides)
 - steady
 - Better computer architectures (course focus)
 - less consistent

Technology: Transistor Revolution

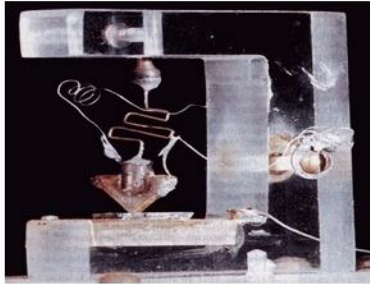

Bell Labs, 1948
First Transistor

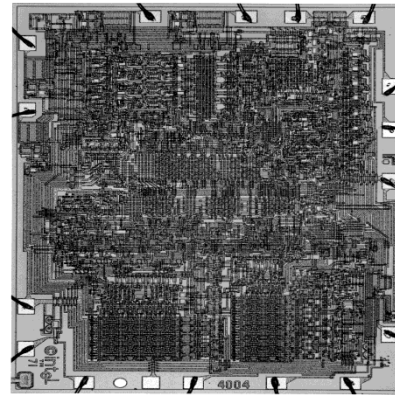

Intel 4004, 1971 (Moore, Noyce Intel 1968)
4-bit
2,300 transistors
740KHz operation
10 μ m (=10000nm) PMOS technology

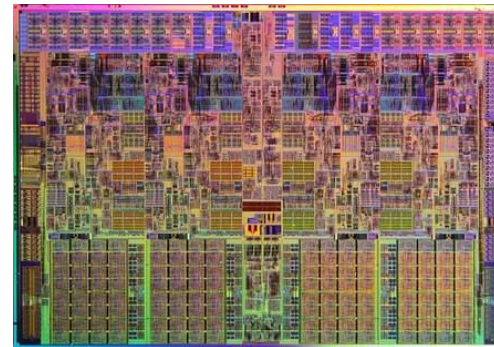
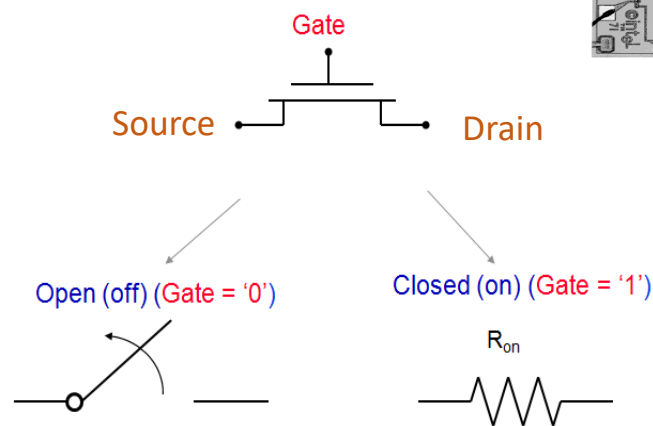

Intel Core i7, 2011
64-bit
2,600,000,000 transistors
3.4GHz
32nm

Technology: Moore's Law

- In 1965, Gordon Moore predicted that the number of transistors that can be integrated on a die would double every 18 months (i.e., grow exponentially with time)
- He made a prediction that semiconductor technology will double its effectiveness every 18 months
- In practice a new technology is introduced every ~two years, with feature sizes of circuit layout 70% of the previous technology

Technology constantly on the move

- Number of transistors is not the limiting factor
 - Currently ~5+ billion transistors/chip
 - Problems: power, heat, latency
- 3-dimensional chip technology?
 - Sandwiches of silicon (Package on Package)
 - “Through-silicon Vias” TSVs for communication
 - FinFET
- On-chip optical connections?
 - Power savings for large packets
- Intel Core i7 (“Ivy Bridge”)
 - 4 cores + GPU
 - 22 nm, tri-gate (“3D”) transistors
 - 1.4B Transistors
 - Shared L3 Cache - 8MB
 - L2 Cache - 1MB (256K x 4) , L1 – 64KB/core

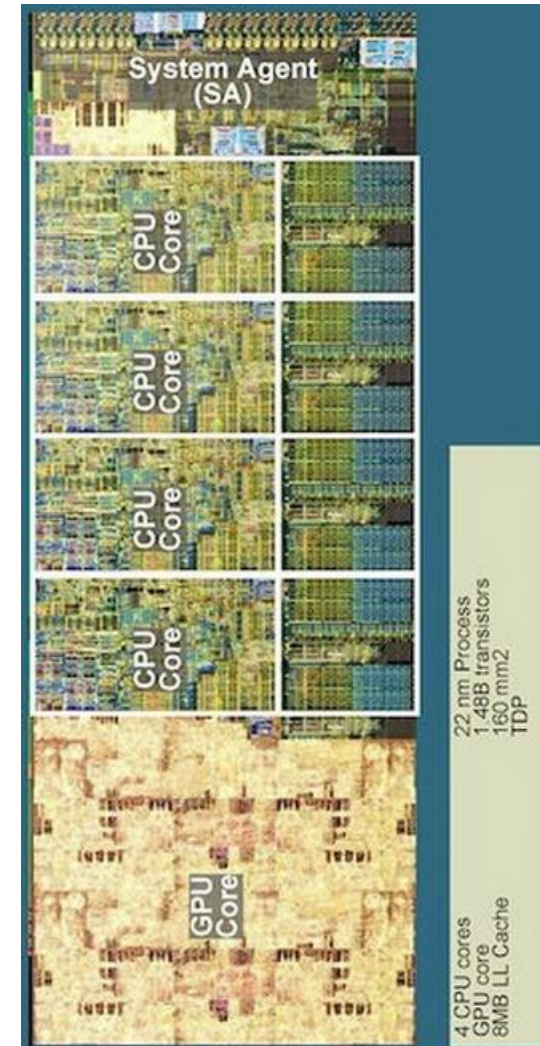

Technology vs microarchitecture: Intel CPU evolution

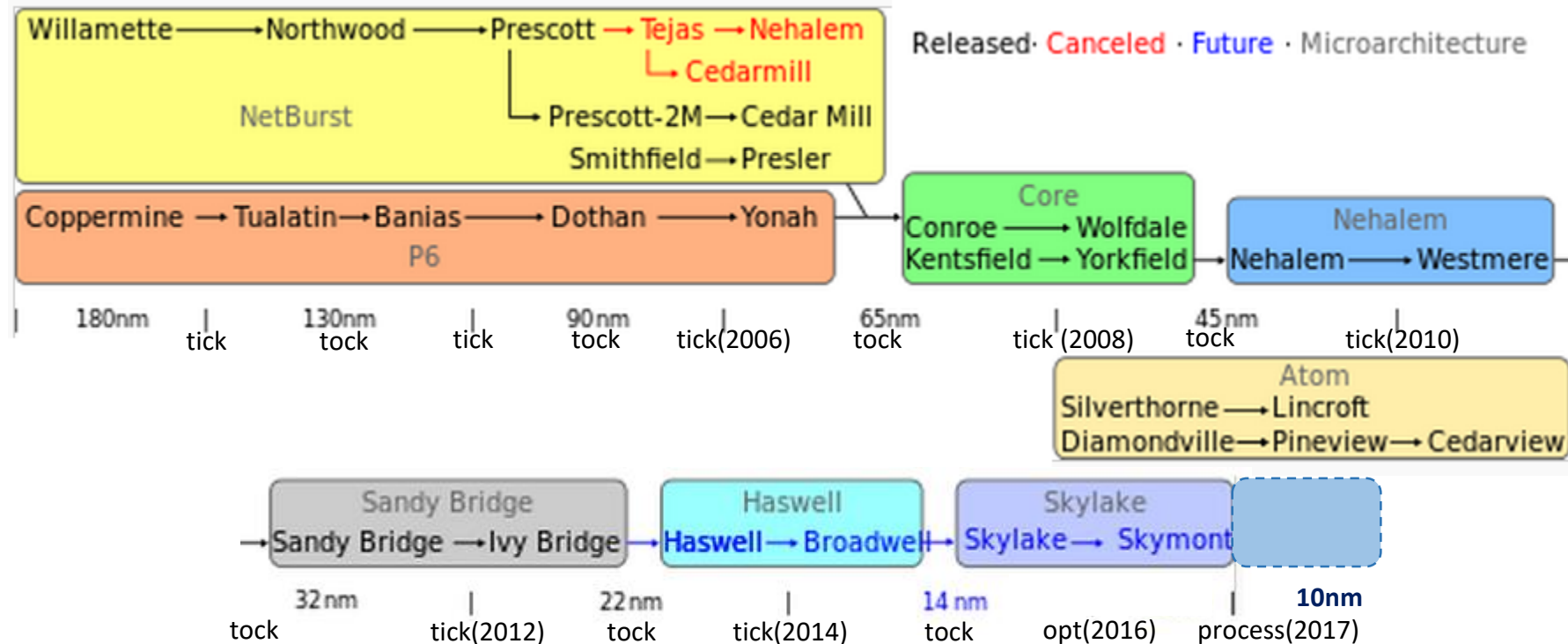

- Kaby Lake optimization step (14nm)
- **Intel announced March 2016: Process-Architecture-Optimization**
- CannonLake upcoming 10 nm successor (process step)
- Ice Lake 10 nm (architecture step)

Transistor size trends and questions

- Feature sizes, higher performance?
 - Transistor size went down from 10 micros to 14 nanometers
 - Quadratic increase in density, linear drop in feature size
 - Linear increase in transistor performance
- Where is the catch?
 - Smaller voltage reduction to maintain safe operation
 - Higher resistance and capacitance per unit of length
 - Shorter wires but with higher resistance/capacitance
 - Wire delays improving poorly compared to transistors

Limiting Force: Power Density

Moore's Law Extrapolation: Power Density for Leading Edge Microprocessors

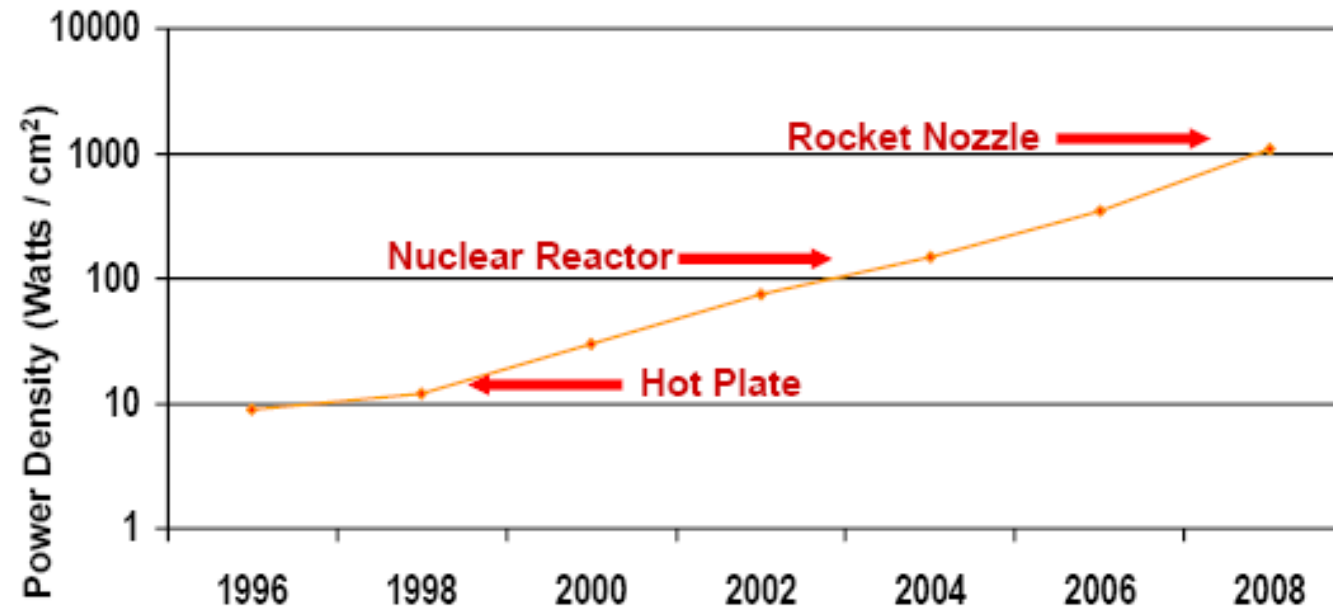

Microprocessor Size $\approx 2 \text{ cm}^2$

Power Density Becomes Too High to Cool Chips Inexpensively

Source: Shekhar Borkar, Intel Corp

Crossroads: Uniprocessor Performance

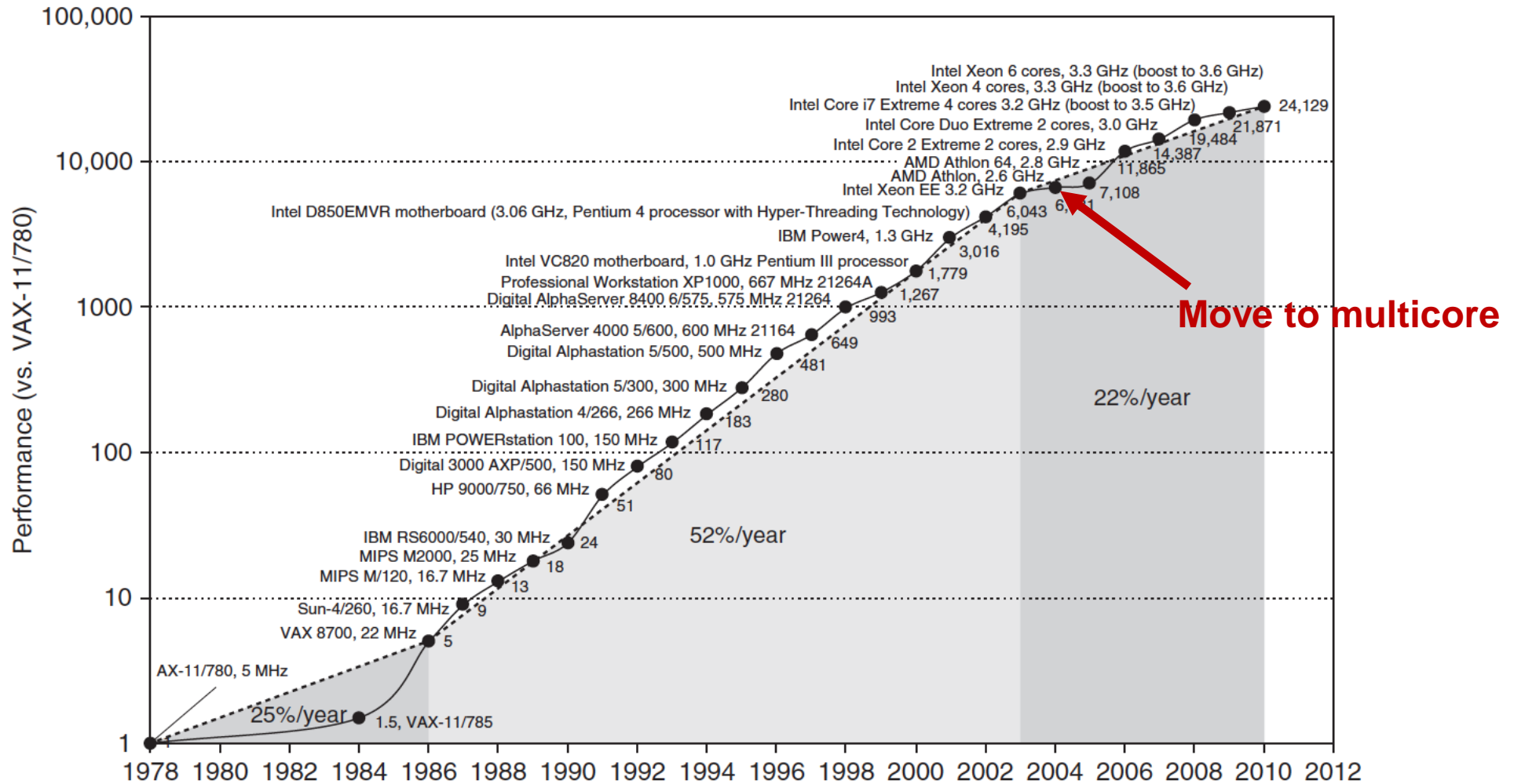

Constrained by power, instruction level parallelism, memory latency

Trends – All in one

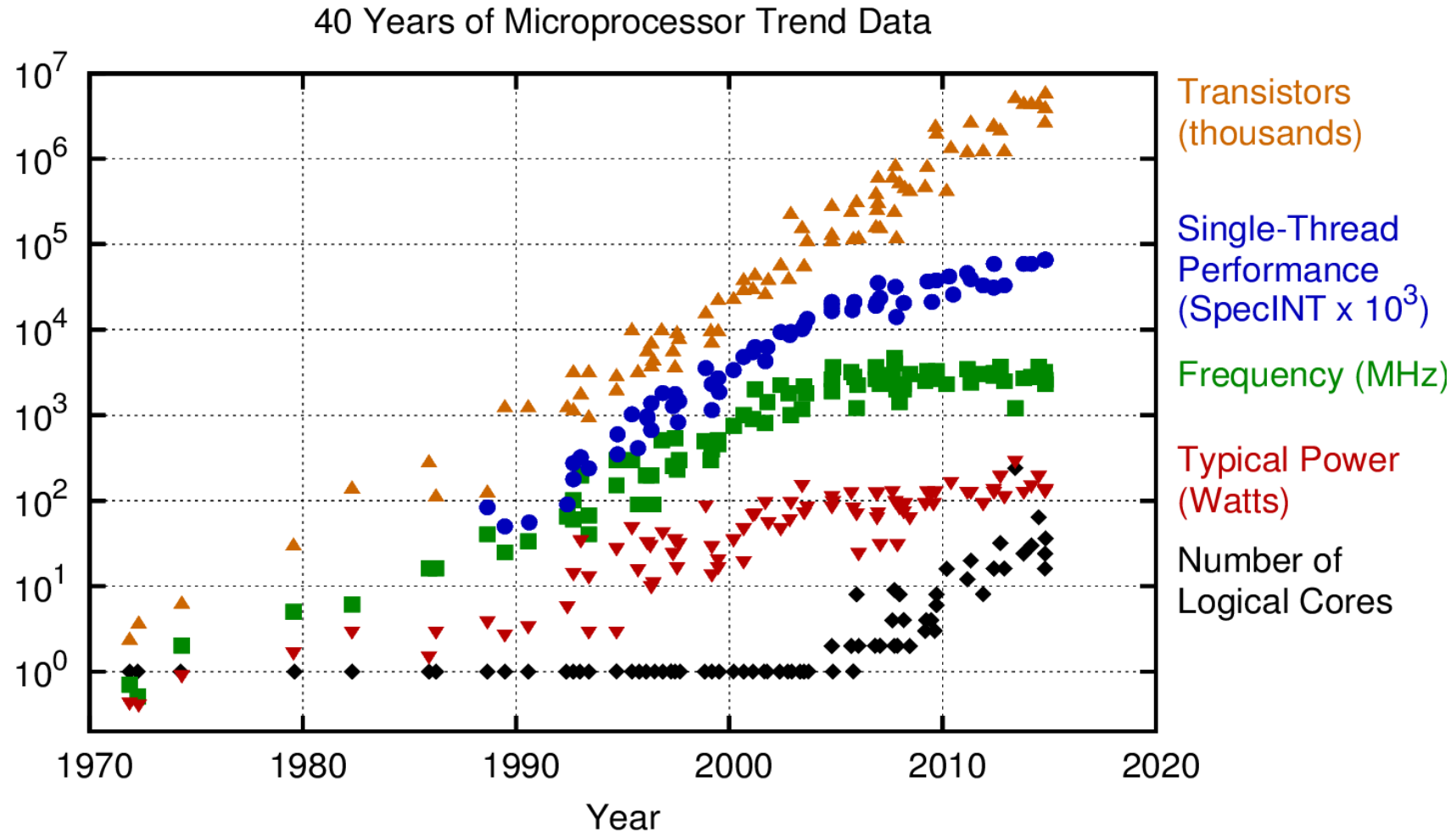

Original data up to the year 2010 collected and plotted by M. Horowitz, F. Labonte, O. Shacham, K. Olukotun, L. Hammond, and C. Batten
New plot and data collected for 2010-2015 by K. Rupp

Trends – All in one

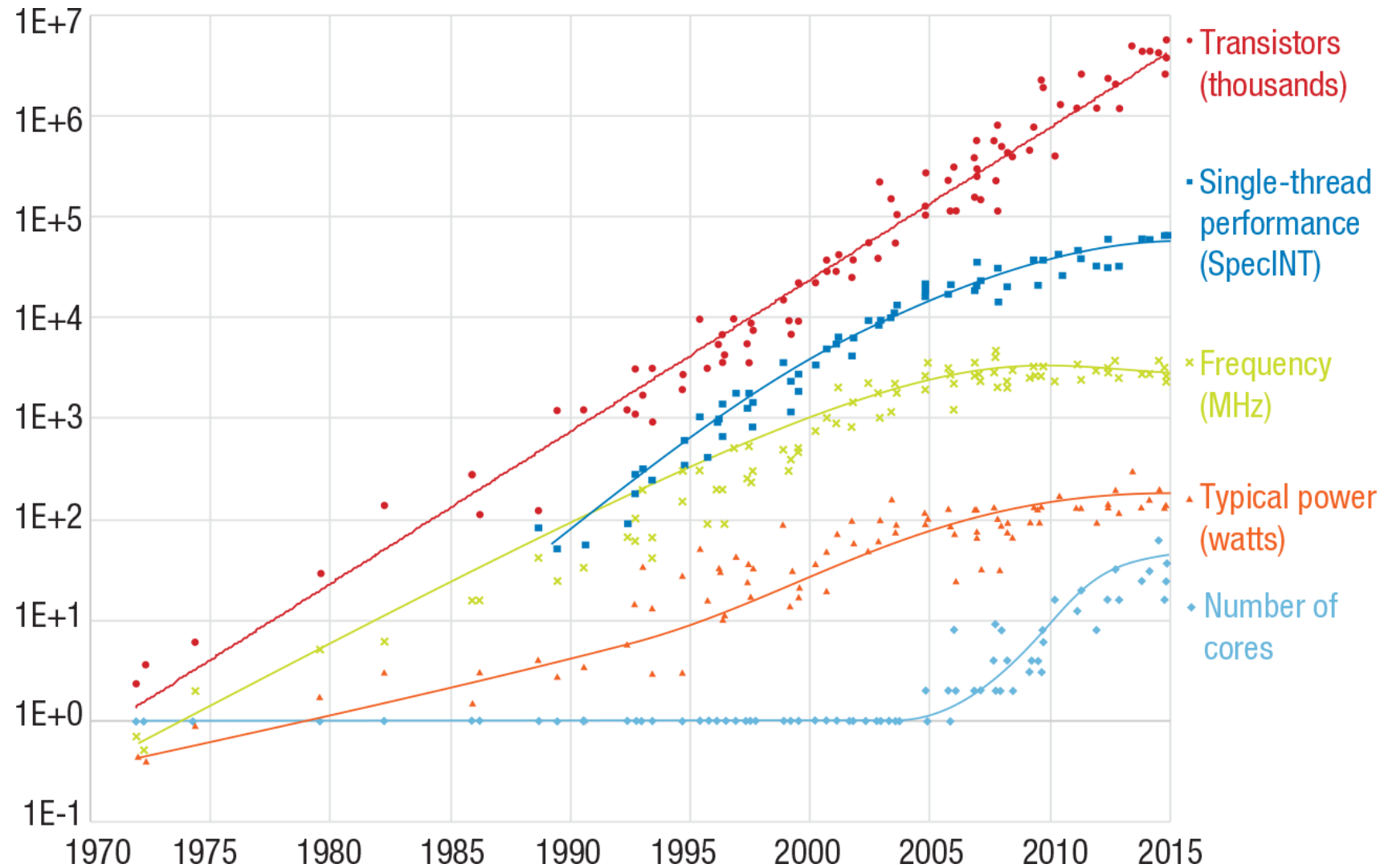

The End of the Uniprocessor Era

- **Power wall:** power expensive, transistors free
 - can put more on chip than can afford to turn on
- **ILP wall:** law of diminishing returns on more HW for ILP
- **Memory wall:** Memory slow, multiplies fast
 - 200 clock cycles to DRAM memory vs. 4 clocks for multiply
- Power Wall + ILP Wall + Memory Wall = Brick Wall
 - Uniprocessor performance now 2X every 5(?) years

Single biggest change in the history of computing systems

Many Core Chips: The future is here

- “Many Core” refers to many processors/chip
 - 64? 128? Hard to say exact boundary
- How to program these?
 - Use 2 CPUs for video/audio
 - Use 1 for word processor, 1 for browser
 - 76 for virus checking???
- Something new is clearly needed here...

Intel 80-core multicore chip,
2007, 65nm – 100M transistors

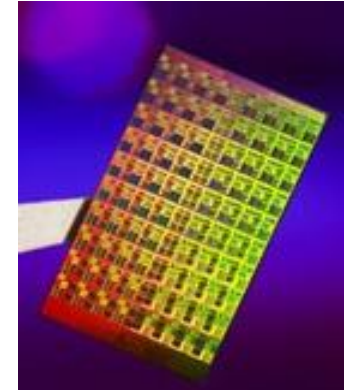

Intel Single-Chip Cloud
Computer (SCC), 48-cores,
2010, 4 memory controllers,
24-router mesh

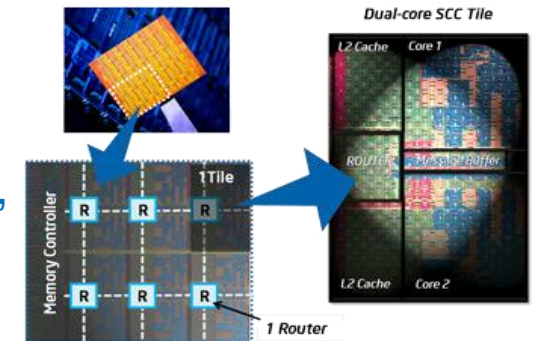

Intel Many Integrated Core
Architecture (MIC), 50-cores,
2012, 22nm, commercial

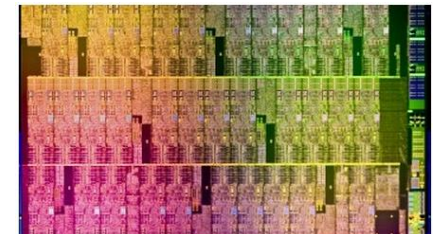

What is Computer Architecture

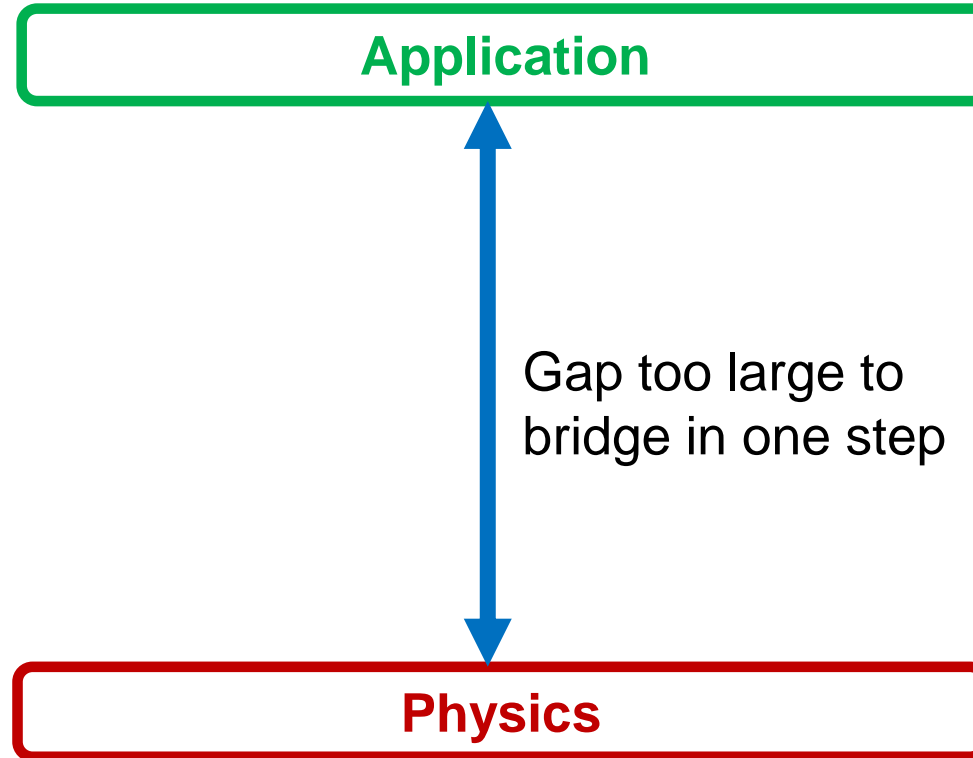

- In its broadest definition, computer architecture is the *design of the abstraction layers* that allow us to implement information processing applications efficiently using available manufacturing technologies.

Abstraction Layers in Modern Systems

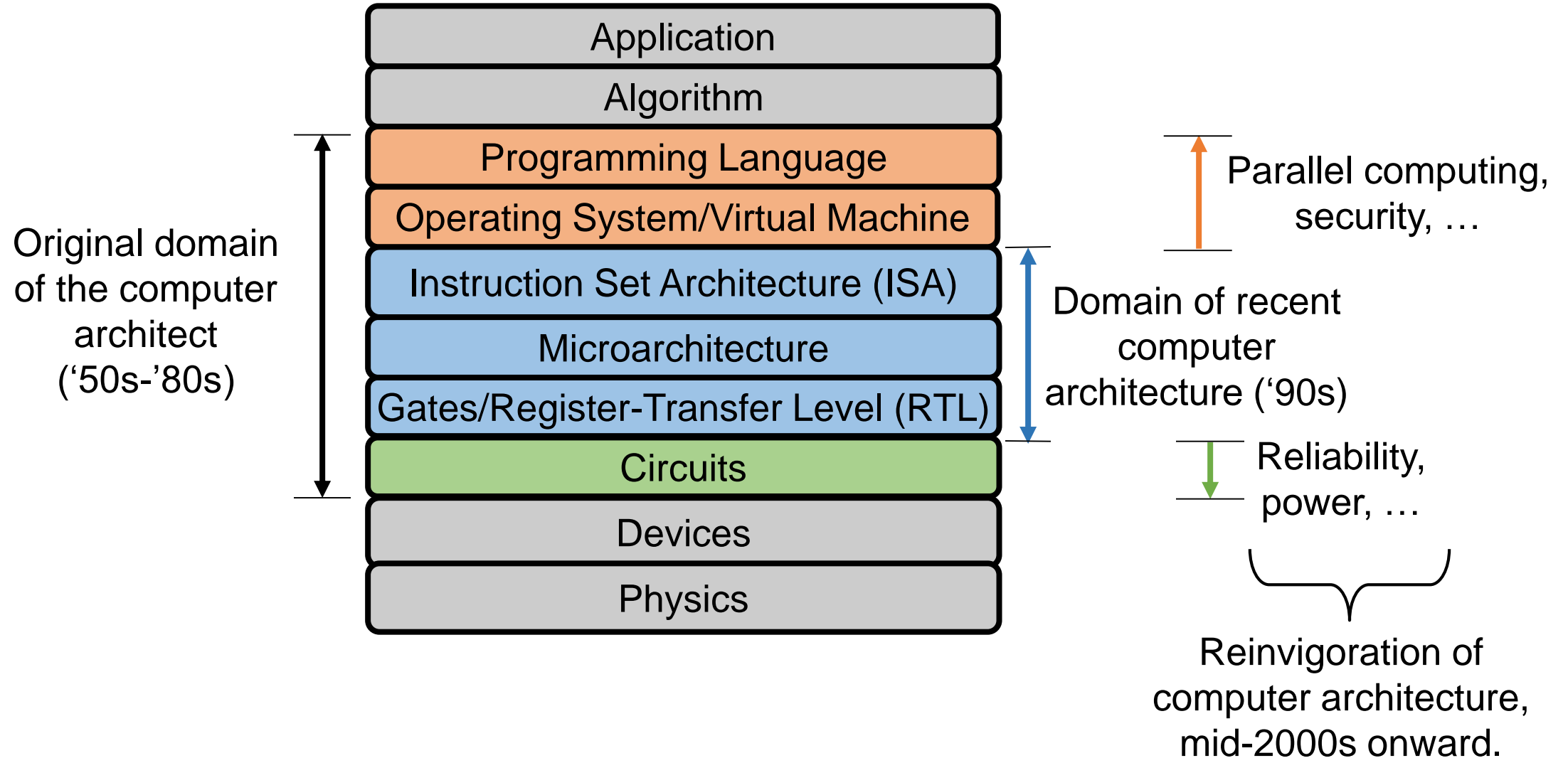

Computer Architecture is an Integrated Approach

- What really matters is the functioning of the complete system
 - hardware, runtime system, compiler, operating system, and application
 - In networking, this is called the “**End to End argument**”
- Computer architecture is not just about transistors, individual instructions, or particular implementations
 - E.g., Original RISC projects replaced complex instructions with a compiler + simple instructions
- It is very important to think across all hardware/software boundaries
 - New technology \Rightarrow New Capabilities \Rightarrow New Architectures \Rightarrow New Tradeoffs
 - **Delicate balance between backward compatibility and efficiency**

Defining Computer Architecture (ISA)

Instruction Set Architecture

- ISAs converged to a common RISC paradigm
 - CISC ISAs implemented on RISC pipelines
- Load-store architectures, general-purpose registers
- Aligned memory addressing, simple addressing modes
- Byte, word, double-word, quad-word operands
- Arithmetic, logic, control operations
- Fixed-length encoding

Example: MIPS R3000

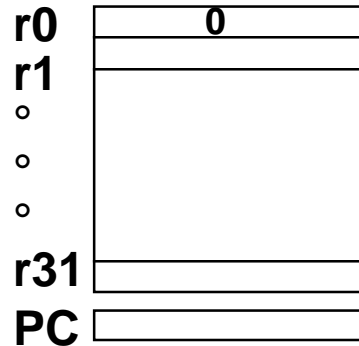

Programmable storage

2^{32} x bytes

31 x 32-bit GPRs (R0=0)

32 x 32-bit FP regs (paired DP)

PC

Data types ?

Format ?

Addressing Modes?

Arithmetic logical

Add, AddU, Sub, SubU, And, Or, Xor, Nor, SLT, SLTU,
AddI, AddIU, SLTI, SLTIU, AndI, OrI, XorI, LUI
SLL, SRL, SRA, SLLV, SRLV, SRAV
MUL, DIV

Memory Access

LB, LBU, LH, LHU, LW, LWL, LWR
SB, SH, SW, SWL, SWR

32-bit instructions on word boundary

Control

J, JAL, JR, JALR
BEq, BNE, BLEZ, BGTZ, BLTZ, BGEZ, BLTZAL, BGEZAL

ISA vs Computer Architecture

- Old definition of computer architecture == instruction set design
 - Other aspects of computer design called implementation
 - Suggests that implementation is uninteresting or less challenging
- Computer architecture >> ISA
- Architect's job much more than instruction set design; technical hurdles today **more** challenging than those in instruction set design

Defining Computer Architecture

Architecture = ISA (+prog. lang.) + Organization + Hardware

- Processor Architecture
 - Pipelining, hazards, ILP, HW/SW interface
- Memory hierarchies
- Interconnects
- I/O systems
- Hardware technology used (e.g. component size)
- Computer architecture focuses on **organization** and **quantitative principles** of design

Execution is not just about HW and ISA

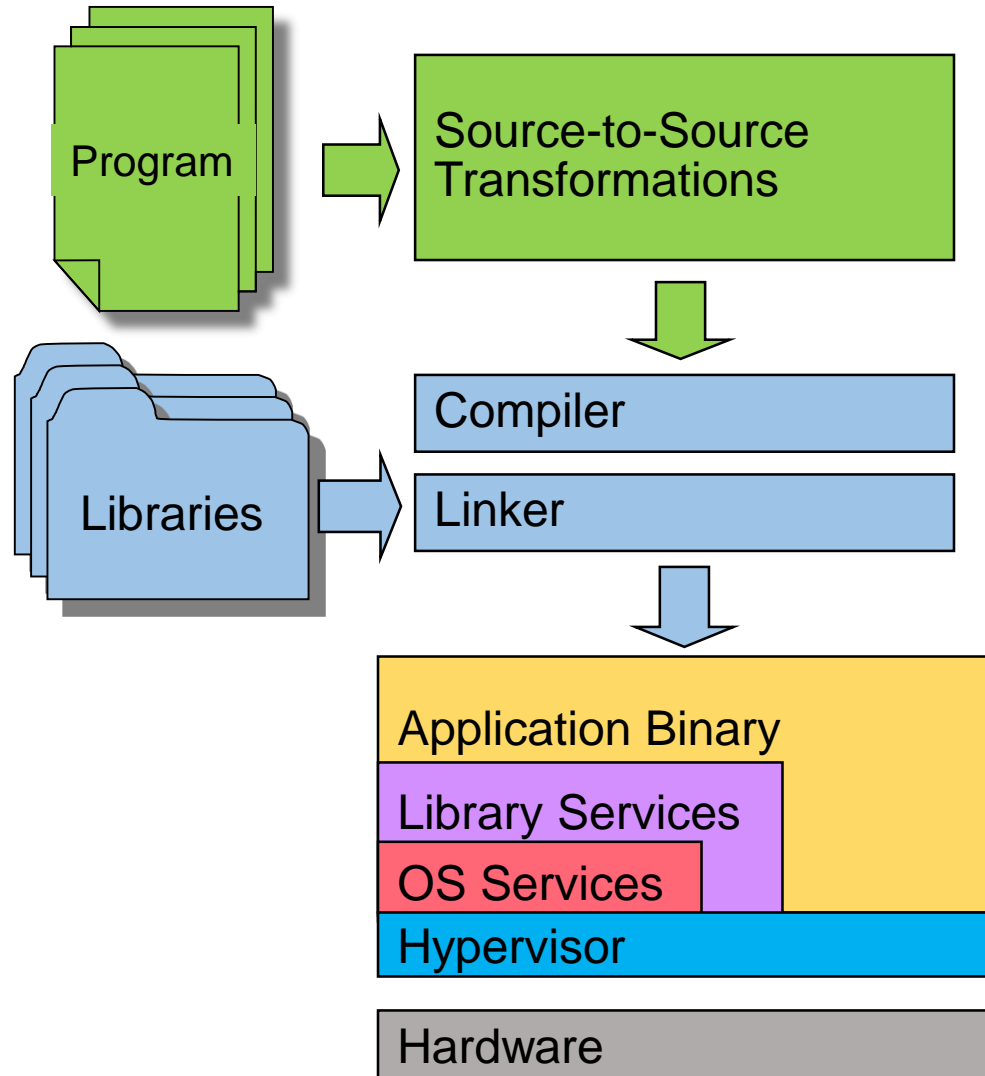

- The VAX fallacy
 - Produce one instruction for every high-level concept
 - Absurdity: Polynomial Multiply
 - Single hardware instruction
 - But Why? Is this really faster???
- RISC Philosophy
 - Full System Design
 - Hardware mechanisms viewed in *context* of complete system
 - Cross-boundary optimization
- Modern programmer does not see assembly language
 - Many do not even see “low-level” languages like “C”.

Computer Architecture Topics

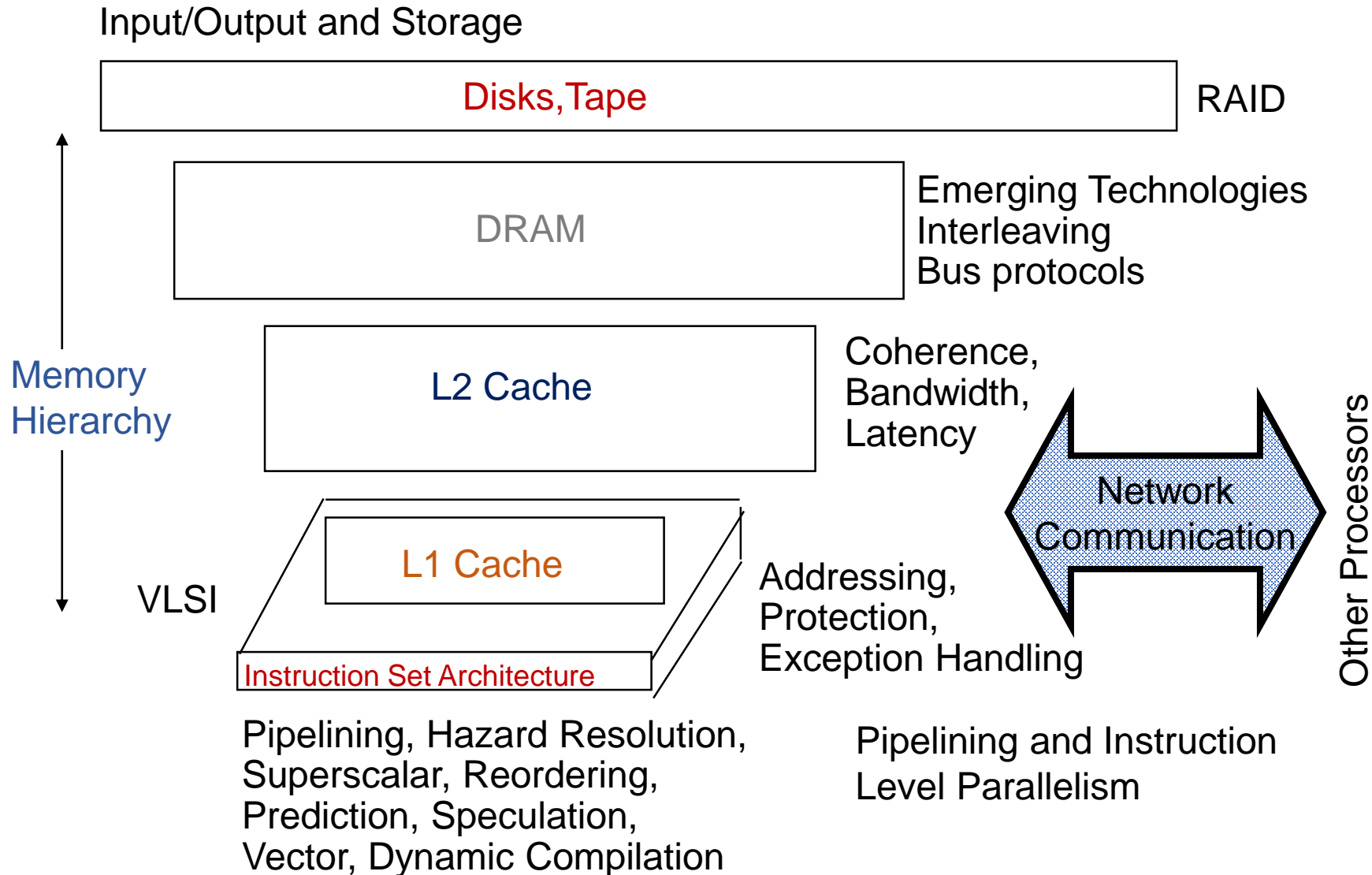

Executive Summary

The processor
you built in
HY225

What you'll
understand
after taking
HY425

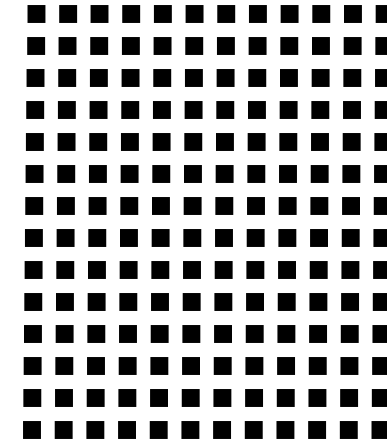
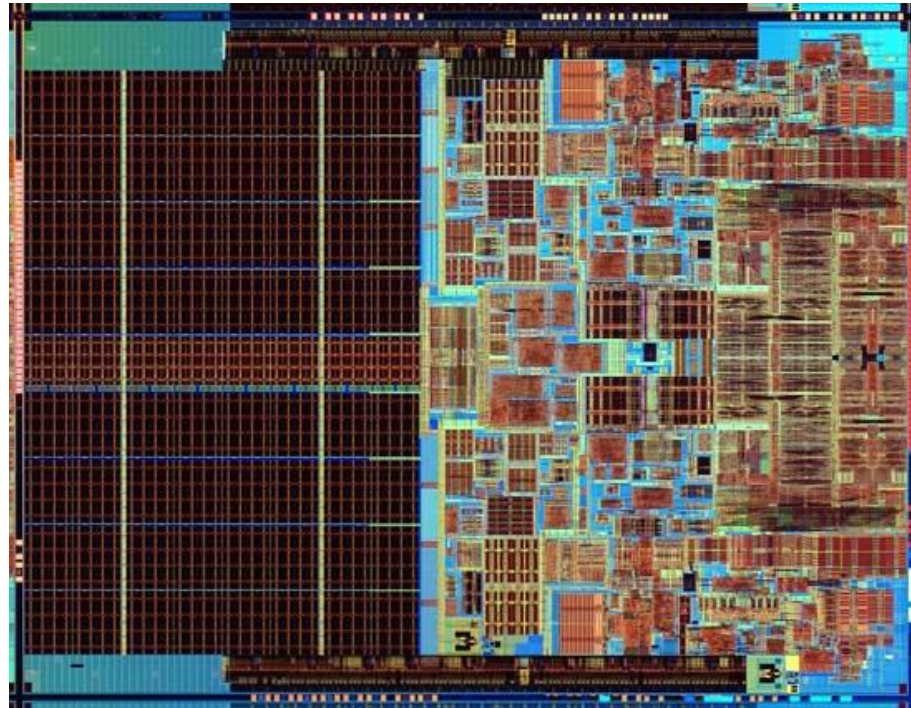

Also, the
technology behind
multi-core
processors

Next Lecture: Major Design Challenges

- Power
- CPU time
- Memory latency/bandwidth
- Storage latency/bandwidth
- Transactions per second
- Intercommunication
- Dependability

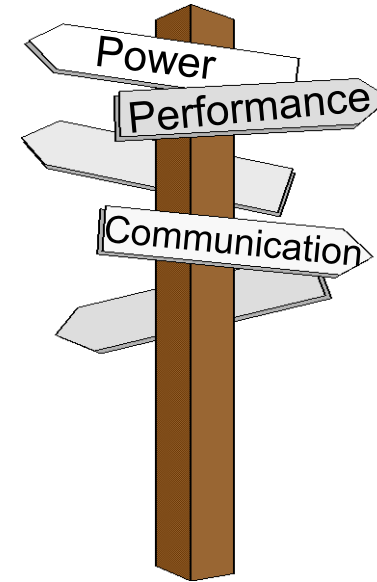

Everything Looks a Little Different