

HY425
Αρχιτεκτονική Υπολογιστών

Branch Prediction

Βασίλης Παπαευσταθίου
Ιάκωβος Μαυροειδής

Branch Prediction

- Πρόβλεψη είναι πλέον απαραίτητη για να έχουμε καλή απόδοση. Γιατί;

```
MULT F0, F1, F2
```

```
DIVD F4, F0, F3
```

```
BNEZ F4, Loop    (EQD F4, F0; BFPF LOOP;)
```

- Σημαντική σε out-of-order ή multi-issue επεξεργαστές (Amdahl's Law)

CPI = Ideal CPI + Structural stalls +

RAW stalls + WAR stalls + WAW stalls + **Control stalls**

- The prediction is a hint that is assumed to be correct, and fetching begins in the predicted direction. If the hint turns out to be wrong, the executed (not committed) instructions from the wrong path are cancelled.
- **3 Θέματα θα λύσουμε: branch prediction, branch target address, cancel branch misprediction (next lecture)**

Πρόβλεψη αποτελέσματος

- Γιατί δουλεύει η πρόβλεψη?
 - Underlying algorithm has regularities.
 - Data that is being operated on has regularities.
 - Instruction sequence has redundancies that are artifacts of way that humans/compiler think about problems.
 - Loops are easy to predict their behaviour

Static Branch Prediction

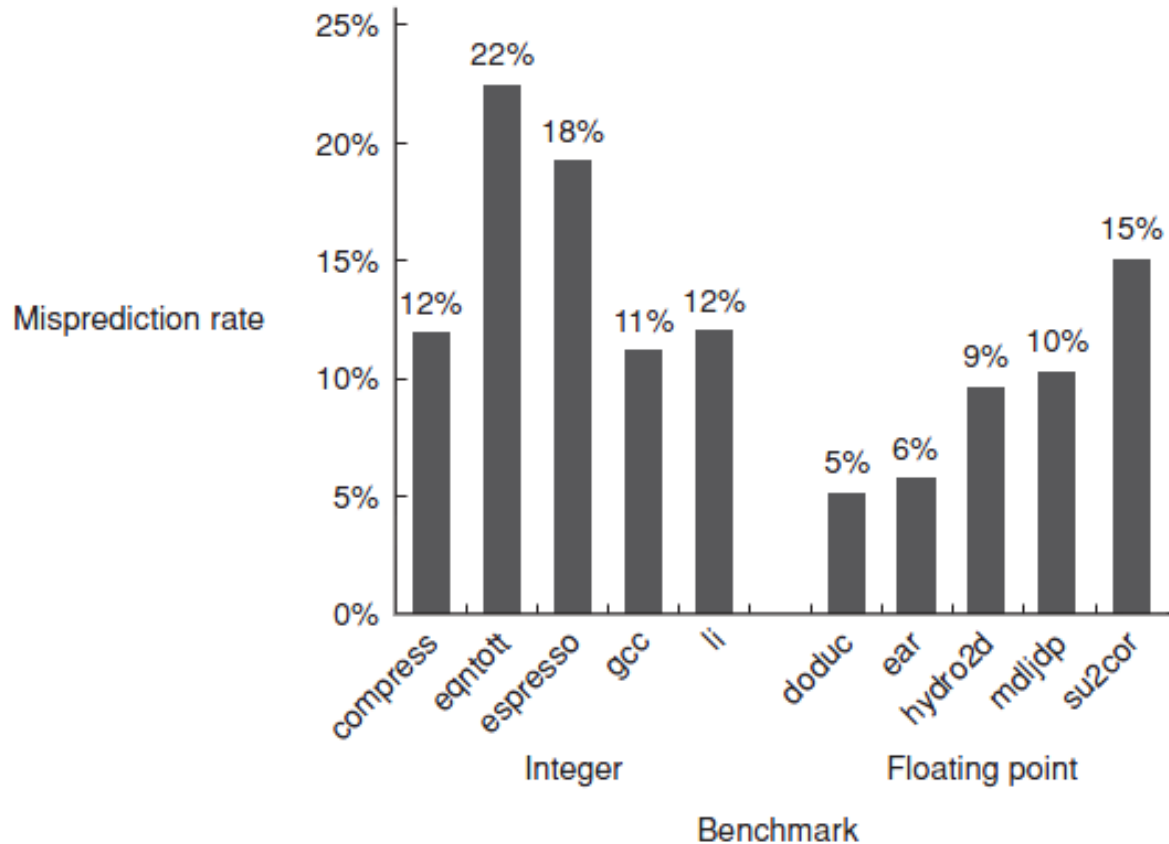

Major limitation : misprediction rate for the integer programs is high

Dynamic Branch Prediction

- Είναι η δυναμική πρόβλεψη καλύτερη από την στατική;
 - Έτσι φαίνεται.
 - Josh Fisher had good paper on “Predicting Conditional Branch Directions from Previous Runs of a Program.” ASPLOS ‘92. In general, good results if allowed to run program for lots of data sets.
 - How would this information be stored for later use?
 - Still some difference between best possible static prediction (using a run to predict itself) and weighted average over many different data sets

Simplest Dynamic Approach: Branch History Table

- Performance = $f(\text{accuracy, cost of misprediction})$
- ***Branch History Table***: Lower bits of PC index 1-bit table
 - Specifies if branch was taken or not the last time
 - When branch delay is longer than time to compute target PC

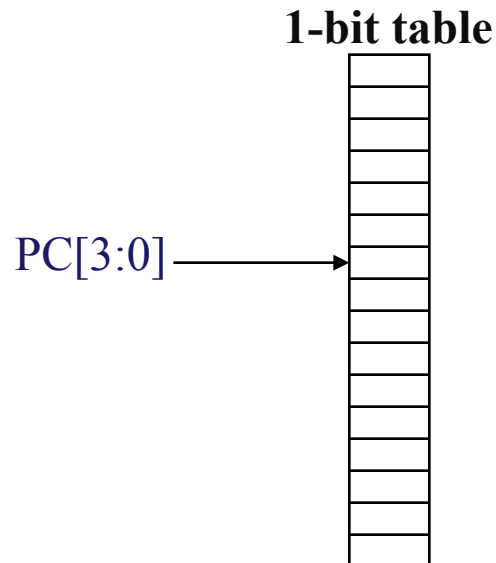

BHT: Πρόβλημα

- **Πρόβλημα**  σε loop, 1-bit BHT προκαλεί 2 mispredictions
 - End of loop case, when it exits instead of looping as before
 - First time through loop on next time through code, when it predicts exit instead of looping

```
Loop: LD    F0,0(R1) ;F0=vector element
      ADDD F4,F0,F2 ;add scalar from F2
      SD    0(R1),F4 ;store result
      SUBI R1,R1,8  ;decrement pointer 8B (DW)
      BNEZ R1,Loop ;branch R1!=zero
      NOP          ;delayed branch slot
```

2-bit Prediction scheme

(Jim Smith, 1981)

- *Λύση* ☞ 2-bit scheme αλλάζει πρόβλεψη μόνο αν γίνει λάθος πρόβλεψη 2 φορές:

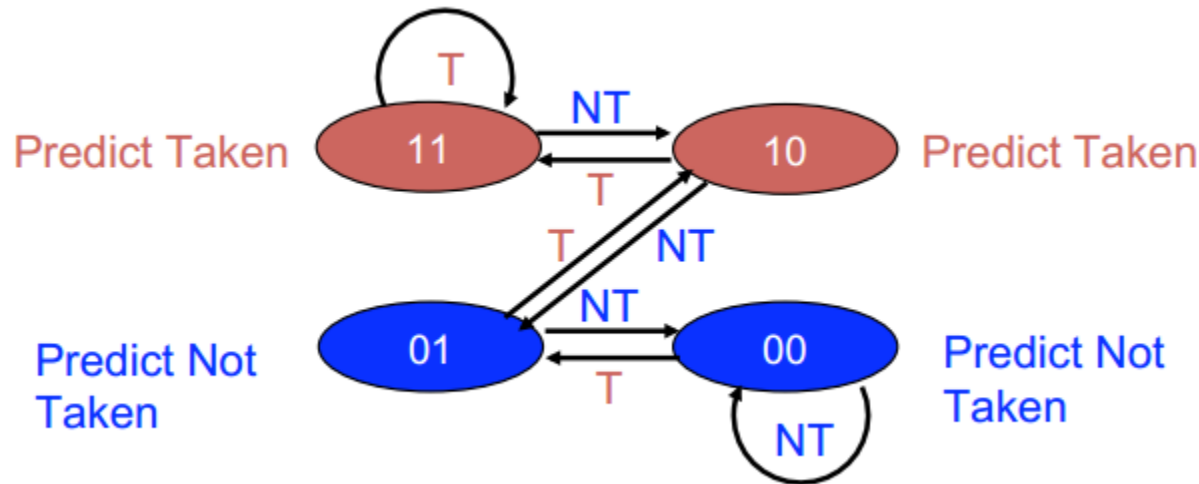

- Κόκκινο: taken
- Μπλε: not taken
- Προσθέτει *hysteresis* στην πρόβλεψη
- Also known as saturation counter or bimodal predictor ⁸

n-bit Predictors

- **n-bit scheme** αλλάζει πρόβλεψη μόνο αν γίνει λάθος πρόβλεψη 2^{n-1} φορές.
- Χρήση **n-bit counter**.
- Μελέτες των n-bit predictors έχουν δείξει ότι οι **2-bit predictors είναι πολύ αποδοτικοί**: τα περισσότερα συστήματα έχουν 2-bit predictors.

Use of Branch History Table

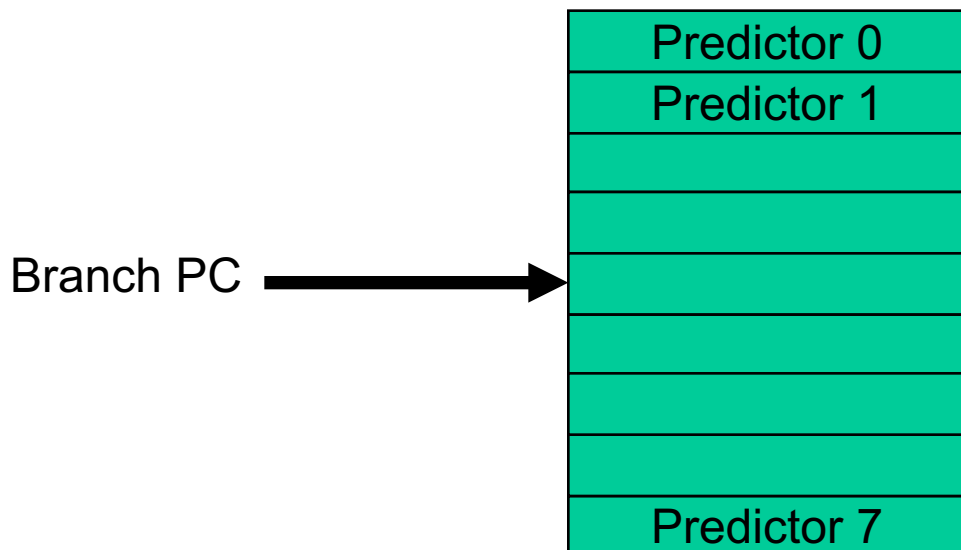

- BHT είναι ένας πίνακας από “Predictors”
 - Usually 2-bit, saturating counters
 - Indexed by PC address of Branch
- Στο ID stage του branch κάνουμε access τον πίνακα. Στο ID stage υπολογίζεται και η διεύθυνση του branch.
(χρειαζόμαστε 1 delay slot)
- Όταν το branch ολοκληρώθει
 - Update corresponding Predictor

2-bit BHT Accuracy

- Λάθος πρόβλεψη επειδή:
 - Wrong guess for that branch
 - Got branch history of wrong branch

SPEC89
benchmarks

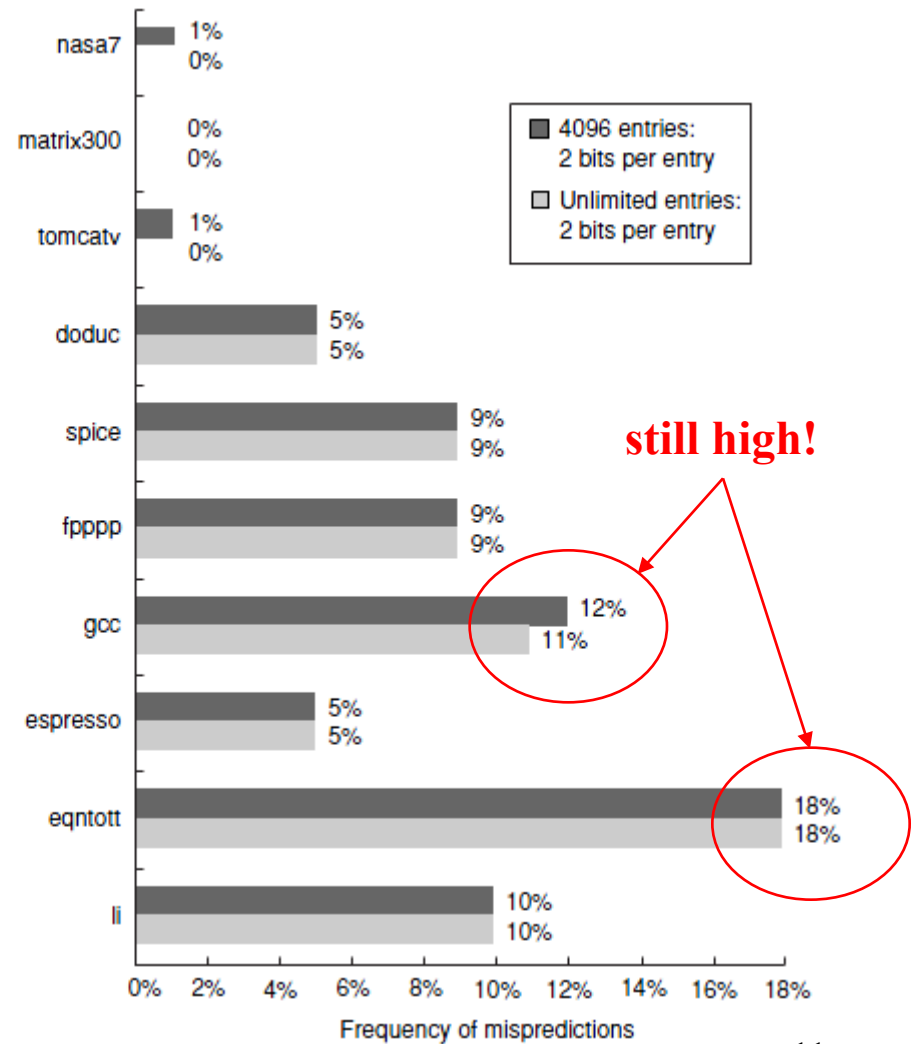

Correlating Predictors

- **Υπόθεση** : πρόσφατα branches συσχετίζονται. Τα αποτελέσματα πρόσφατων branches επηρεάζουν την πρόβλεψη του τρέχον branch.
- **Παράδειγμα 1 (από eqntott benchmark)**:

Example in C

```
if (aa==2)
    aa=0;
if (bb==2)
    bb=0;
if (aa != bb) {...}
```

Example in assembly

```
          DSUBUI      R3, R1, #2
          BNEZ        R3, L1          ;branch b1 (aa!=2)
          DADD        R1, R0, R0      ;aa=0
L1:       DSUBUI      R3, R2, #2
          BNEZ        R3, L2          ;branch b2 (bb!=2)
          DADD        R2, R0, R0      ;bb=0
L2:       DSUBU       R3, R1, R2      ;R3=aa-bb
          BEQZ        R3, L3          ;branch b3 (aa==bb)
```

If branches b1 and b2 are both not taken (i.e. first two if statements are true) then b3 will be taken

Correlating Predictors

- *Παράδειγμα 2:*

Example in C

```
if (d==0)
    d=1;
if (d==1) {...}
```

Example in assembly

```
        BNEZ      R1,L1      ;branch b1 (d!=0)
        DADDIU   R1,R0,#1    ;d==0, so d=1
L1:     DADDIU   R3,R1,#-1
        BNEZ      R3,L2      ;branch b2 (d!=1)
...
L2:
```

Possible execution sequences

Initial value of d	d==0?	b1	Value of d before b2	d==1?	b2
0	yes	not taken	1	yes	not taken
1	no	taken	1	yes	not taken
2	no	taken	2	no	taken

Example: (4,2) Predictor

(4,2) GHT (Global History Table) predictor

- 4 means that we keep four bits of history
- 2 means that we have 2 bit counters in each slot.
- Then behavior of recent branches selects between, say, 16 predictions of next branch, updating just that prediction
- Note also that aliasing is possible here...

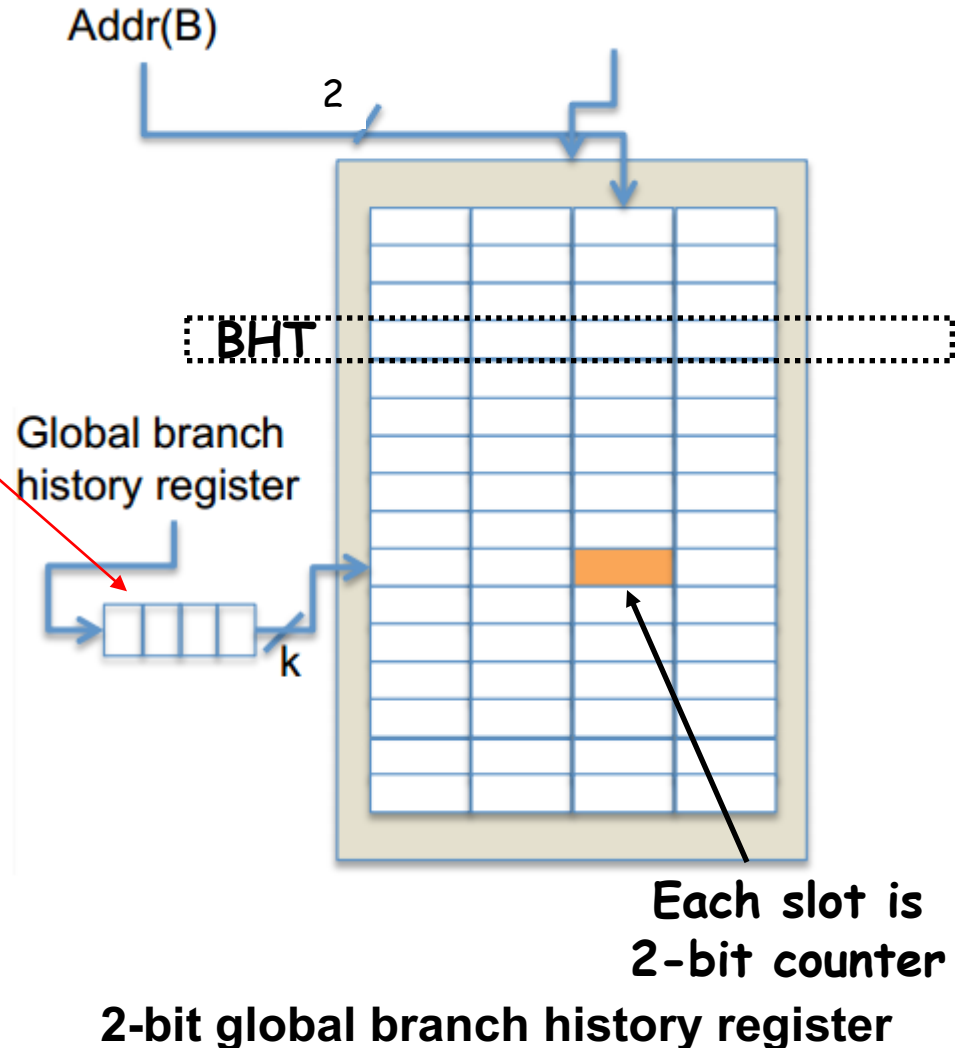

Correlating Branches

(k,n) GHT predictor

- k means that we keep k-bits of history
- n means that we have n-bit counters in each slot.
- Note that the original two-bit counter solution would be a (0,2)

GAp predictor

- Συνολική μνήμη :

$$2^k * 2^{\text{addr_size}} * n =$$

$$2^{k+\text{addr_size}} * n$$

- Trivial amount of additional HW

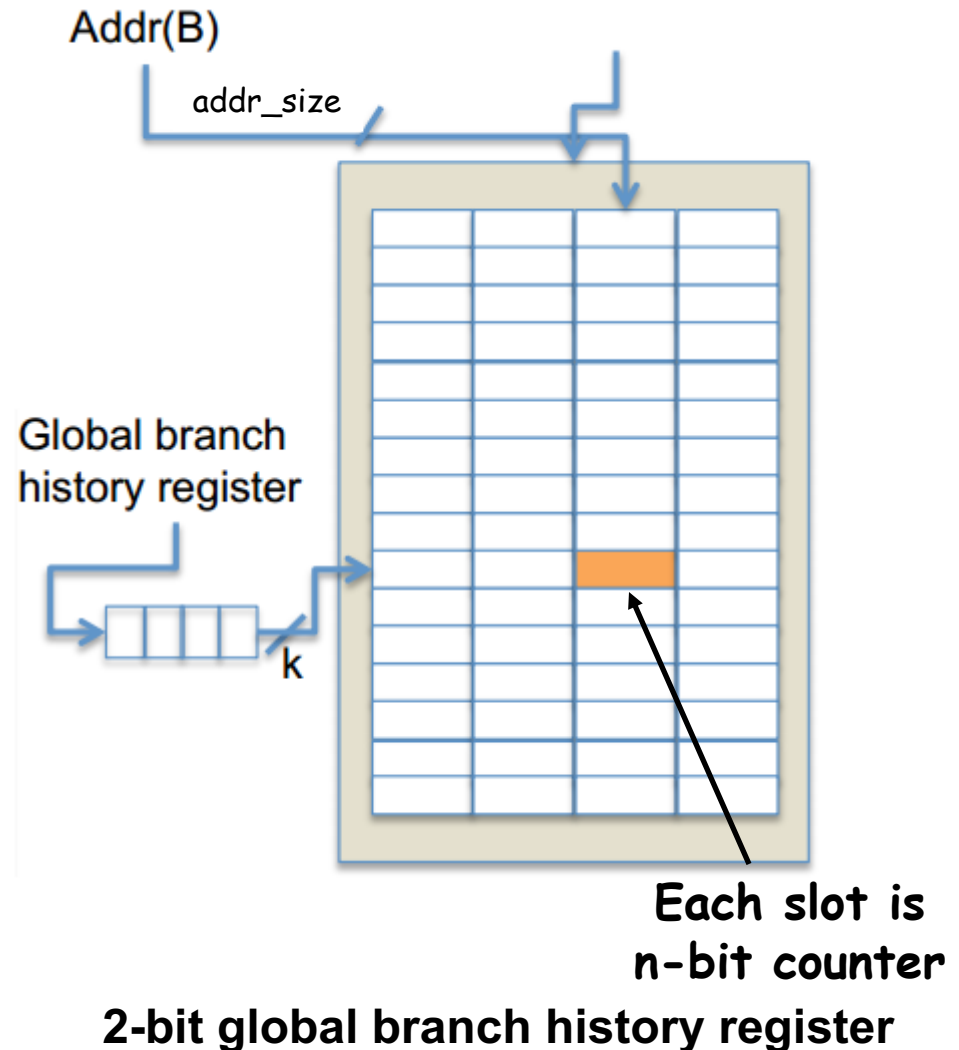

Yeh and Patt's classification

Taxonomy of two-level branch predictors

- ▶ XAy predictor
- ▶ $X=G$, global history register
- ▶ $X=P$, per-branch history register
- ▶ $X=S$, per-set-of-branches history register
- ▶ $y=g$, global branch history table
- ▶ $y=p$, per-branch history table
- ▶ $y=s$, set-associative per branch history table
 - ▶ Set-associative mapping of branch PCs reduces conflicts (aliases)

Yeh and Patt's classification

- *First Level:*

- τα k πιο πρόσφατα branches που εκτελέστηκαν οπουδήποτε
Produces a “**GA** y ” (for “global address”) in the Yeh and Patt classification

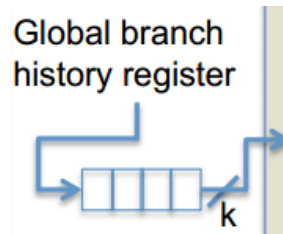

- τα k πιο πρόσφατα αποτελέσματα του ίδιου branch.
Produces a “**PA** y ” (for “per address”) in same classification (e.g. PA g)

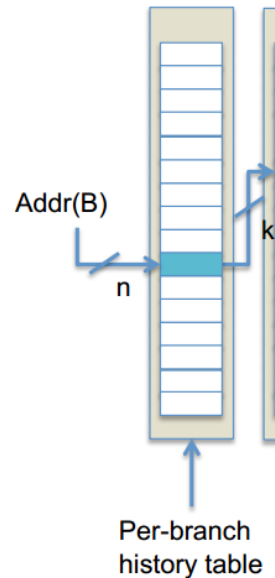

Yeh and Patt's classification

- *Second Level:*
 - Single entry for any branch “*XAg*”
 - Per branch history table “*XAp*”

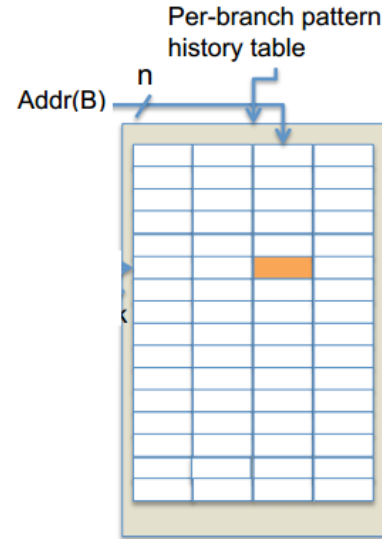

- Per set history table “*XAs*”

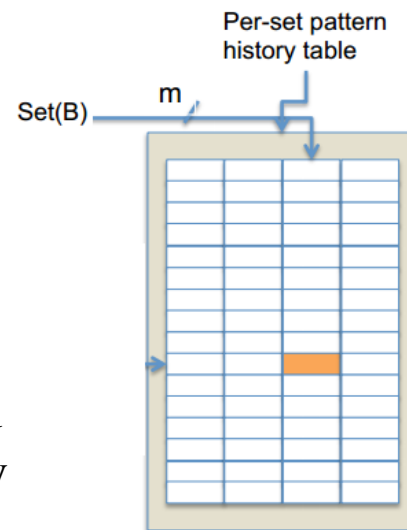

The set attribute of a branch can be determined by the branch opcode, branch class assigned by a compiler, or branch address.

Yeh and Patt's classification

Variations of two-level branch predictors

Variation	Description
GAg	Global Adaptive Branch Prediction using one global pattern history table
GAs	Global Adaptive Branch Prediction using per-set (of branch PCs) pattern history tables
GAp	Global Adaptive Branch Prediction using per-address (of branch PC) pattern history tables
PAg	Per-address Adaptive Branch Prediction using global pattern history table
SAg	Per-Set Adaptive Branch Prediction using global pattern history table
SAs	Per-Set Adaptive Branch Prediction using per-set pattern history tables
SAp	Per-Set Adaptive Branch Prediction using per-address pattern history tables

Yeh and Patt's classification

Global history predictors

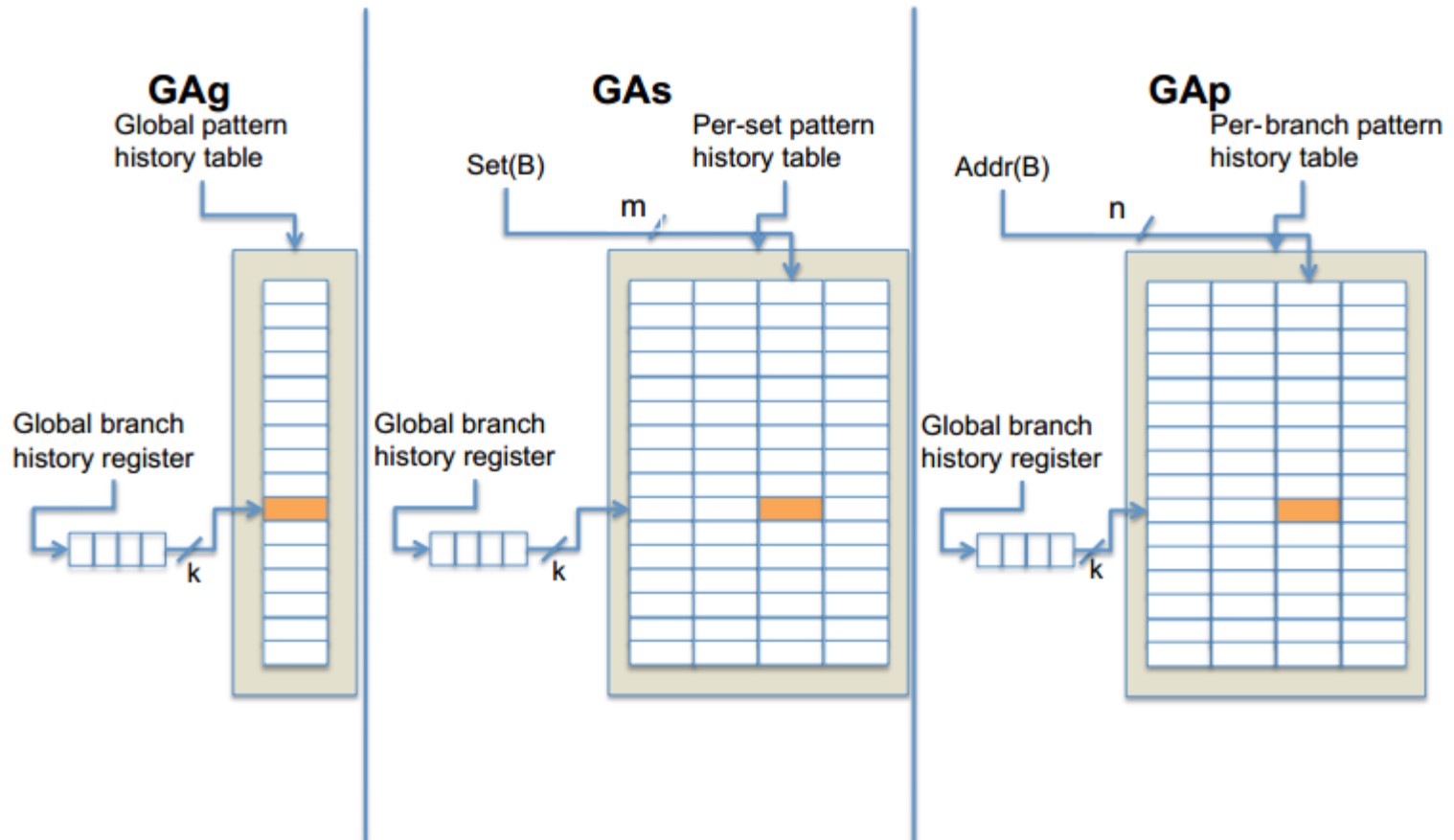

Yeh and Patt's classification

Per-branch history predictors

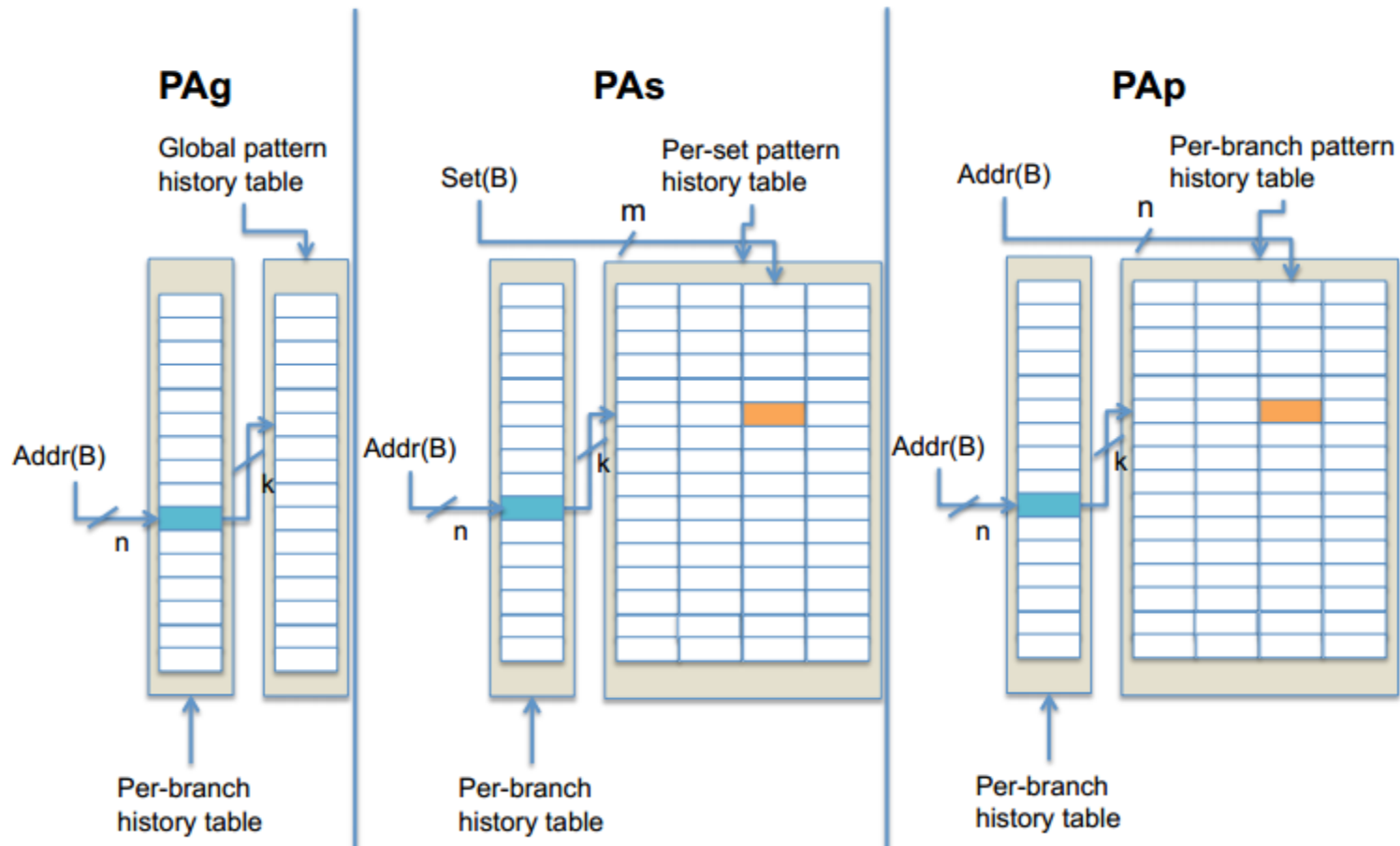

Yeh and Patt's classification

Per-set history predictors

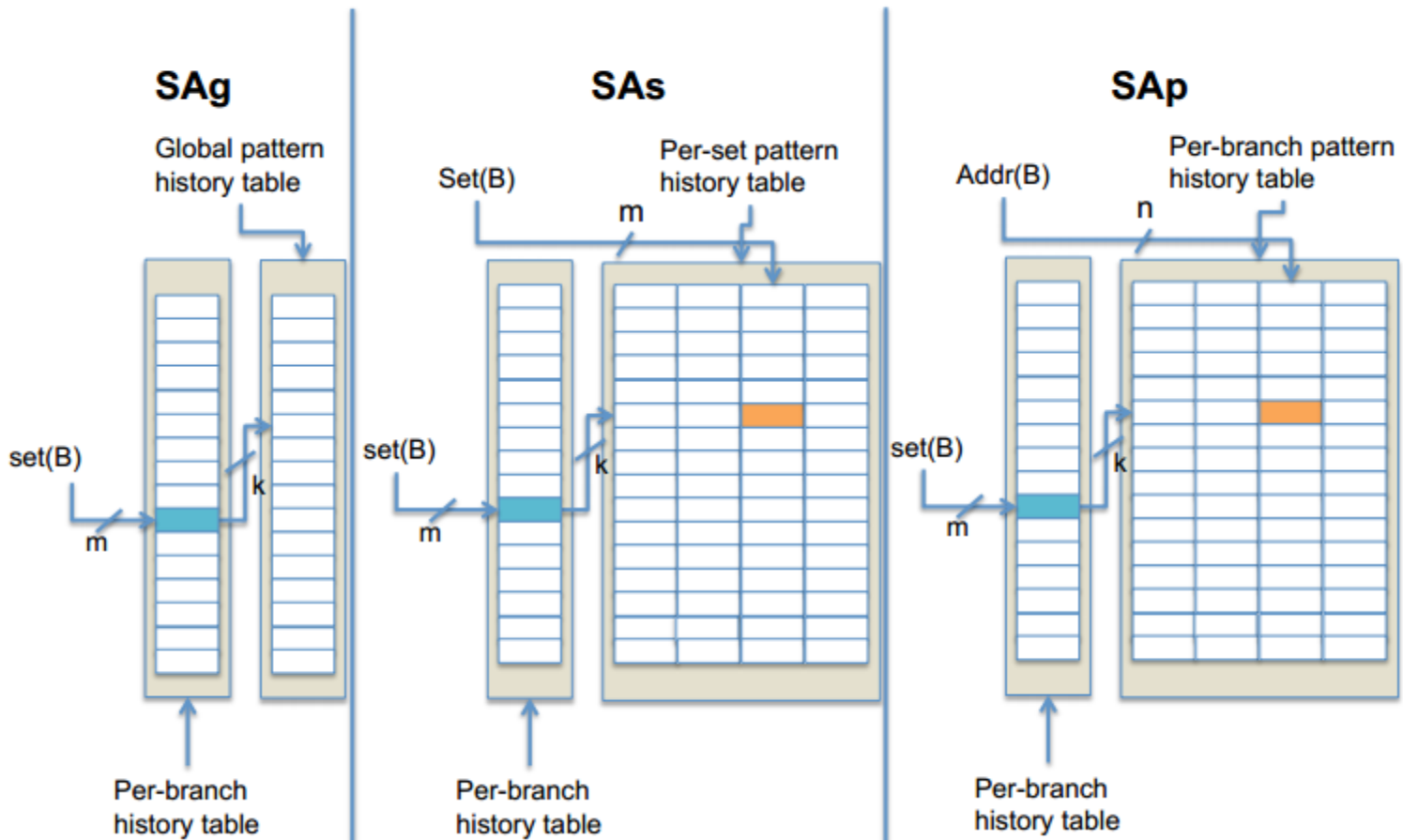

Accuracy of Different Schemes

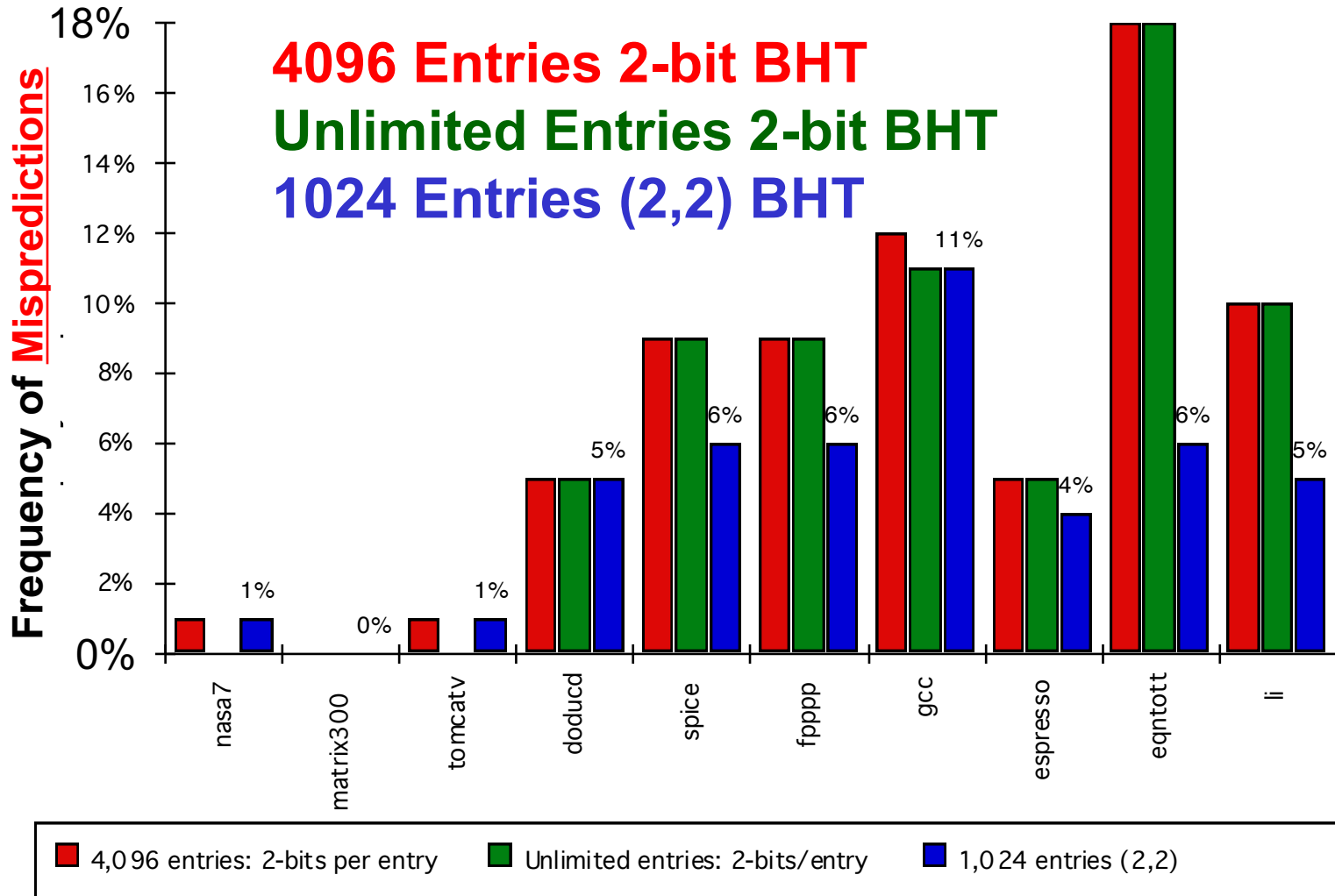

Branch Target Buffer

- Ένα look up table με διευθύνσεις των predicted taken branches. Όταν κάνει match στέλνει το target PC του branch.
- *Optimization*: Store the predicted-taken branches only

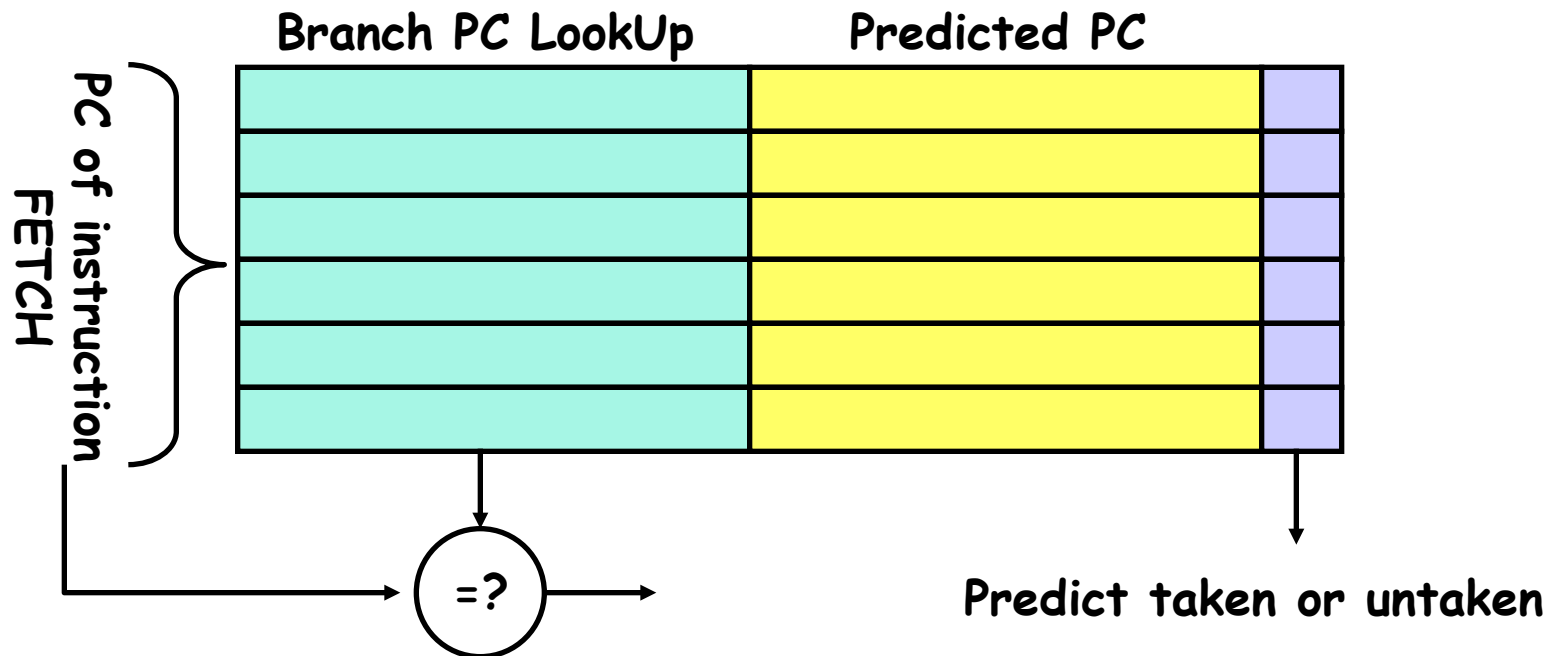

Branch Target Buffer

- Το Branch Target Buffer (BTB) γίνεται access στο IF stage: γλυτώνουμε 1 κύκλο.

IF	ID	EX
Send PC to memory and BTB.	Send Out predicted PC if entry found in BTB	Update BTB

Instruction in buffer	Prediction	Actual branch	Penalty cycles
yes	taken	taken	0
yes	taken	not taken	2
no		taken	2
no		not taken	0

Branch Folding

- Αποθήκευσε μία ή περισσότερες target instructions μαζί με target address στο Branch Target Buffer (BTB).
 - Χρόνος πρόσβασης στον BTB μπορεί να μεγαλώσει.
 - Zero-cycle branches: Αντικατέστησε την branch εντολή με την target instruction.

Indirect Jumps

- Indirect procedure calls, select ή case statement, gotos. Πλειοψηφία είναι procedure returns.
- **Πρόβλημα** 📖 accuracy low when procedure is called from multiple sites.
- **Λύση** 📖 small buffer of return addresses operating as a stack. This structure caches the most recent return addresses: pushing a return address on the stack at a call and popping one off at a return.

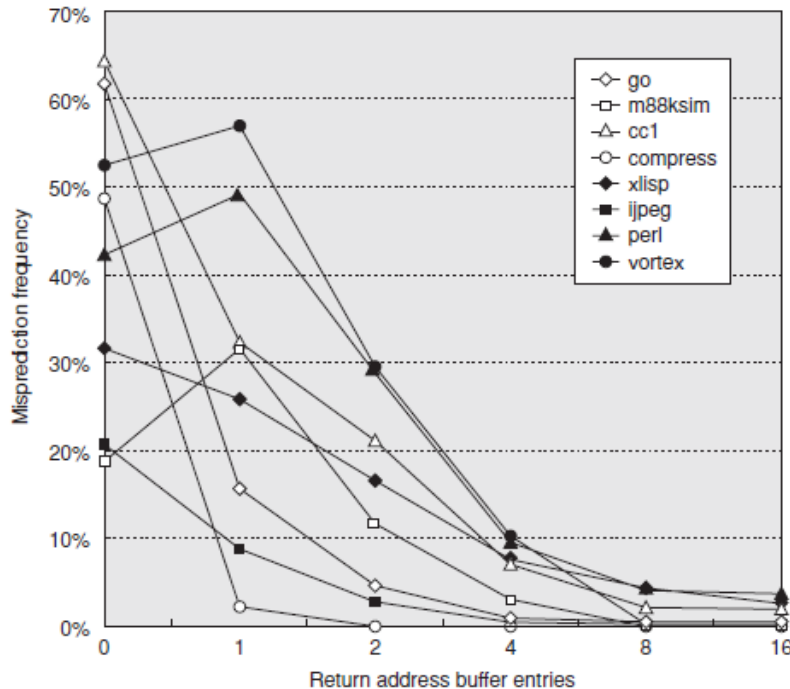

In SPEC95 benchmarks,
procedure returns account for
more than 15% of the branches

Predicated Execution

- Απόφυγε branch prediction μετατρέποντας τα branches σε conditionally executed instructions:

if (x) then A = B op C else NOP

- If false, then neither store result nor cause exception
 - Expanded ISA of Alpha, MIPS, PowerPC, SPARC have conditional move; PA-RISC can annul any following instr.
 - IA-64: 64 1-bit condition fields selected so conditional execution of any instruction
-
- Αρνητικά των conditional instructions
 - Still takes a clock even if “annulled”
 - Stall if condition evaluated late
 - Complex conditions reduce effectiveness; condition becomes known late in pipeline

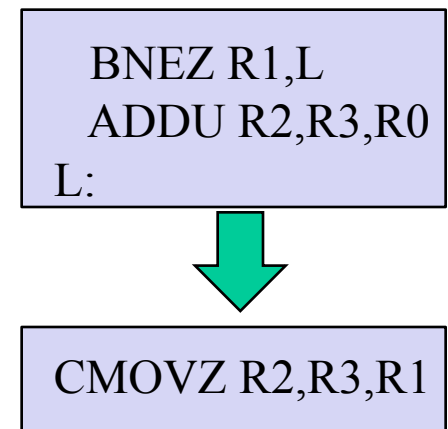
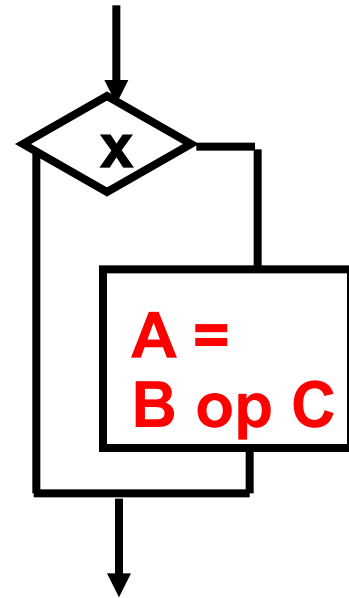

Dynamic Branch Prediction

- Η πρόβλεψη είναι ιδιαίτερα σημαντική για την απόδοση του συστήματος.
 - Prediction is exploiting “information compressibility” in execution
- **Branch History Table:** 2 bits for loop accuracy
- **Correlation:** Recently executed branches correlated with next branch.
 - Either different branches (GA)
 - Or different executions of same branches (PA).
- **Branch Target Buffer:** include branch address & prediction
- **Predicated Execution** μπορούν να ελαττώσουν τον αριθμό των branches, αριθμό των λάθους προβλέψεων.