

---

# DC Motor 1/2

---

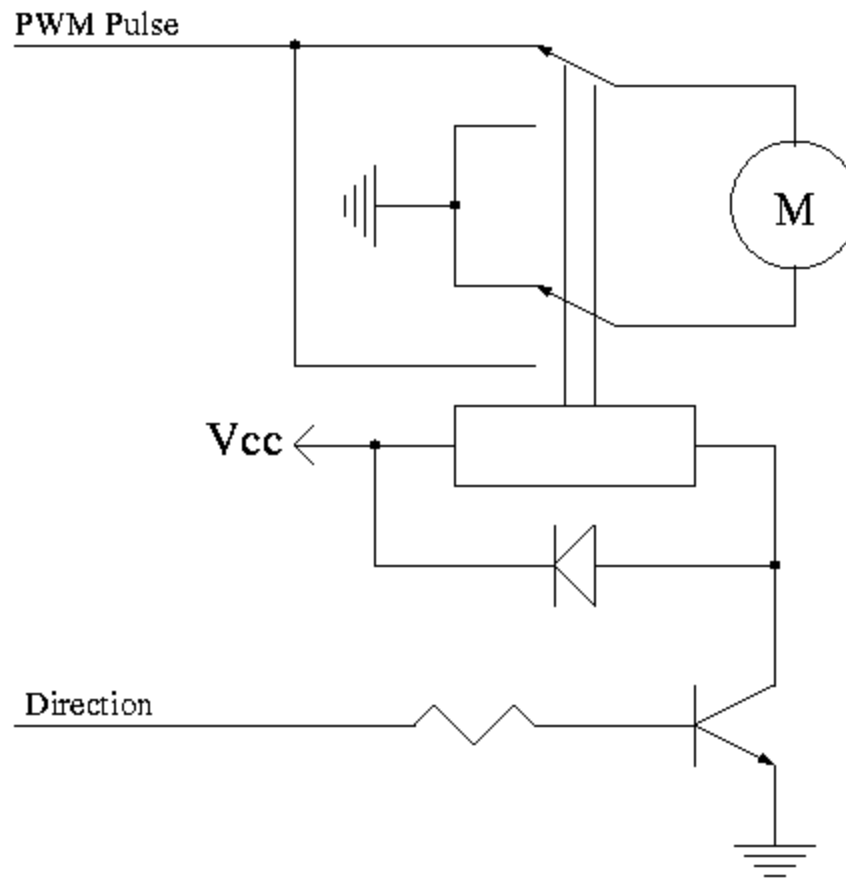

# DC Motor 2/2

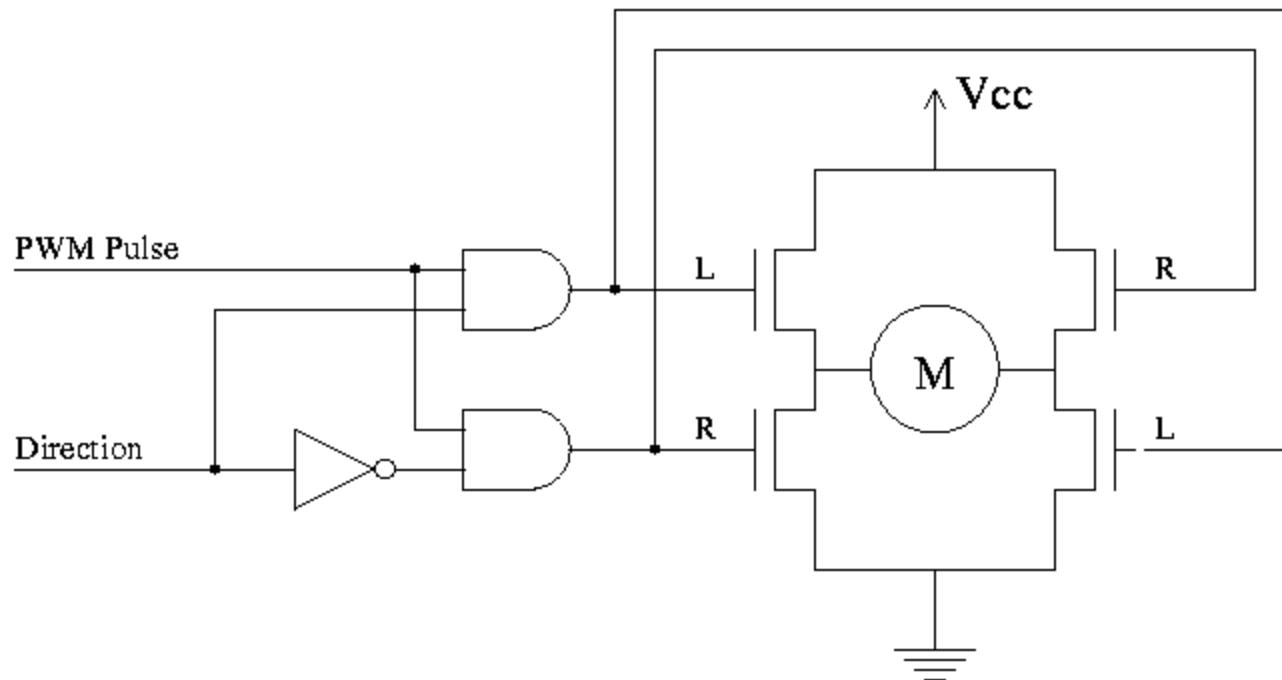

---

# DC Motor Controller

---

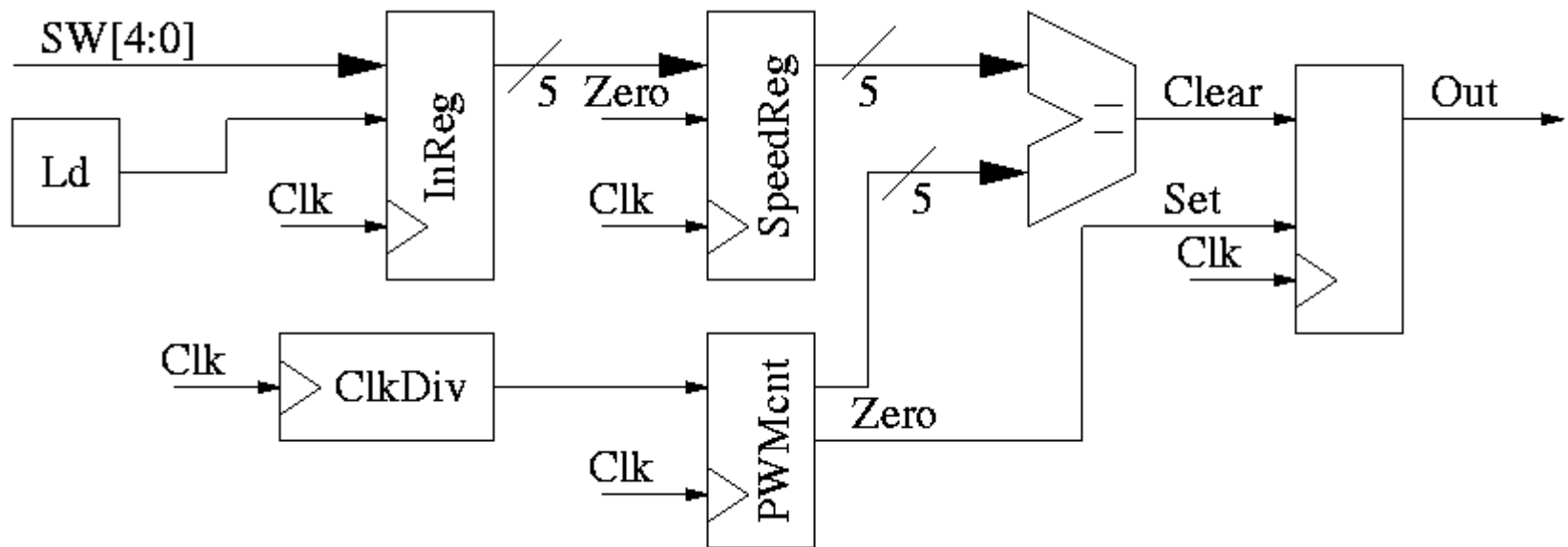

---

# Step Motor Full Step

---

Step	Q0	Q1	Q2	Q3
1	1	0	0	1
2	1	0	1	0
3	0	1	1	0
4	0	1	0	1

---

# Step Motor Half Step

---

Step	Q0	Q1	Q2	Q3
1	1	0	1	0
2	1	0	0	0
3	1	0	0	1
4	0	0	0	1
5	0	1	0	1
6	0	1	0	0
7	0	1	1	0
8	0	0	1	0

---

# Full Step FSM

---

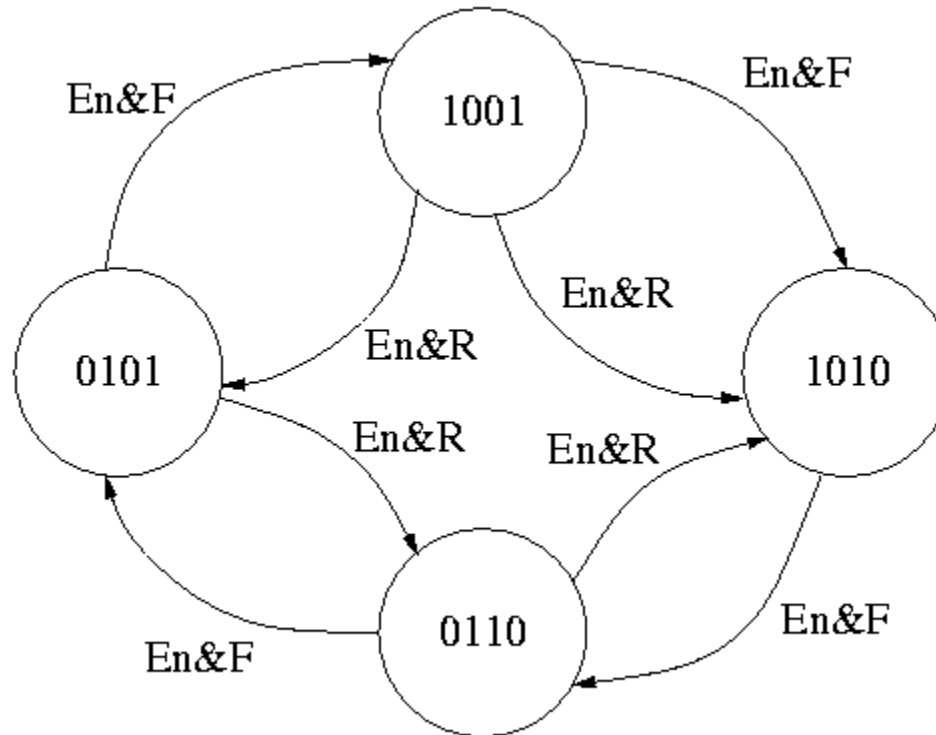

---

# Step Motor Controller

---

