

4. Time-Space Switching and the family of Input Queueing Architectures

4.1 Intro: Time-Space Sw.; Input Q'ing w/o VOQ's

4.2 Input Queueing with VOQ's: Crossbar Scheduling

4.3 Adv.Topics: Pipelined, Packet, Enveloppe Scheduling

4.4 Comb. Input-Output Q'ing (CIOQ) – Int. Speedup

4.5 Comb. Input-Crossp. Q'ing – Buffered Crossbars

4.6 Partitioned Crossbars

Manolis Katevenis

CS-534 – Univ. of Crete and FORTH, Greece

<http://archvlsi.ics.forth.gr/~kateveni/534/>

4.1 Introduction to Input Queueing

Table of Contents:

- Time-Space Switching
 - the crossbar scheduling problem
- “Naïve” Input Queueing without VOQ's (Input Buffering)
 - independent per-output schedulers
 - head-of-line (HOL) blocking
 - performance analysis results

(Single-Stage) Space Switching: the Crossbar

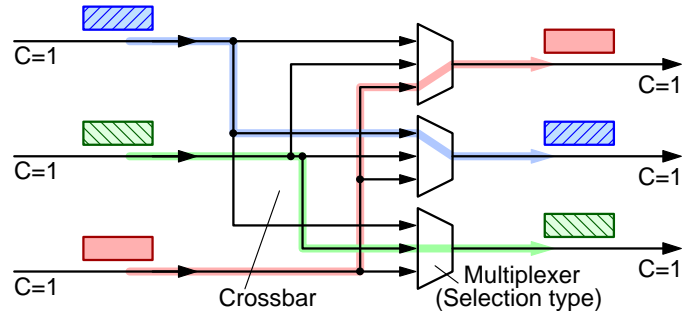

- when a single (time-switched) path does not suffice for aggregate traffic...
- Space Switching: multiple simultaneously-active paths exist
- Crossbar: the single-stage, non-blocking space switch
- Output Contention: no two inputs allowed to simultaneously feed same output
 ⇒ need input buffers to alter the time relationship of conflicting packets

Time-Space-Time Circuit Switch

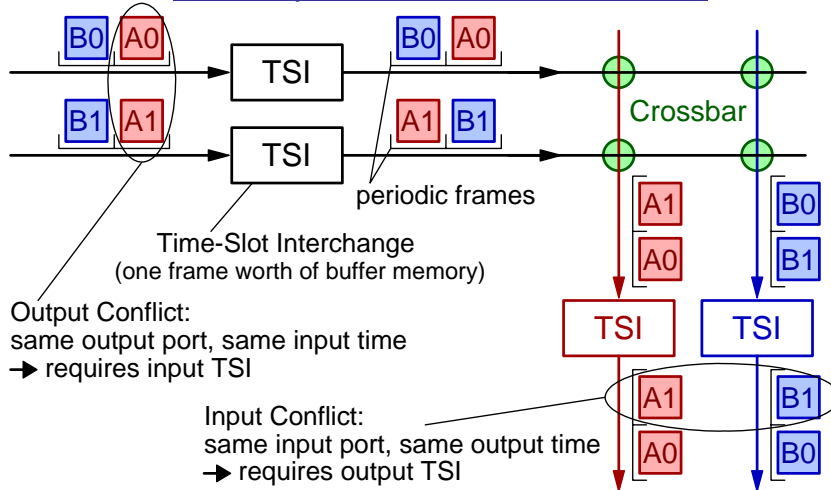

- Time switching (TSI's) needed to resolve output and input conflicts
- In packet switching: no strict output timing req'mnts ⇒ may skip output TSI

The *Static* Crossbar Scheduling Problem in Ckt Sw'ng

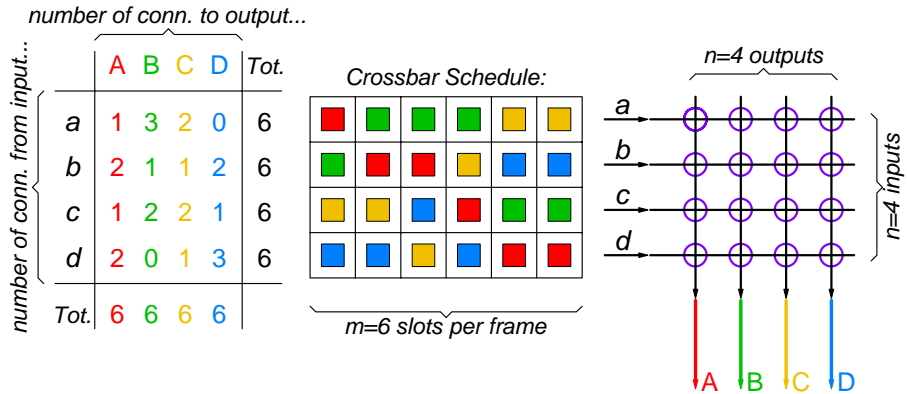

- Given the number of connections requested from each input to each output (left matrix), find a schedule (middle)

4.1 - U. Crete - M. Katevenis - CS-534

5

Building the Schedule one Step at a Time

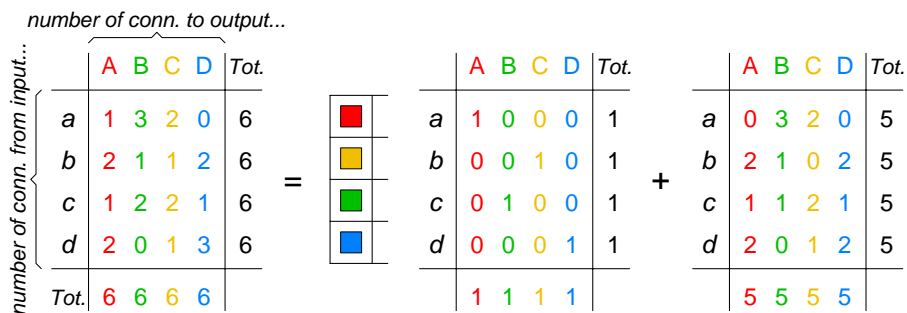

- Decompose the (full) request matrix into the sum of a permutation matrix plus a "smaller" (full) request matrix [not obvious how to do –e.g. what if we start b-A, c-B, d-C ?]
- What about requests arriving one-at-a-time? (exercises 9)

4.1 - U. Crete - M. Katevenis - CS-534

6

The Input Queueing Family in Packet Switching

- Per-input buffer memories
- + Scalable: each memory needs throughput = 2 \Rightarrow feasible *independ. of N*
- + Low cost: total memory thrupt = $2 \cdot N$ – same as shared buffer

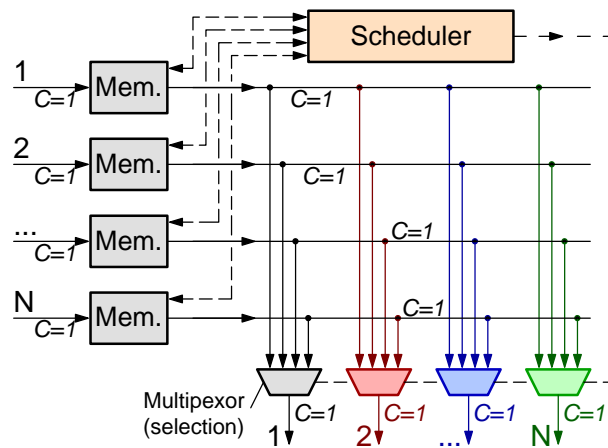

- Performance suffers a lot, unless (i) multiple queues per input, and (ii) sophisticated scheduler, and usually (iii) other modifications to be seen later (small crosspoint Q's, or internal speedup and OQ's)

4.1 - U. Crete - M. Katevenis - CS-534

7

Input Queueing is *not* the dual of Output Queueing

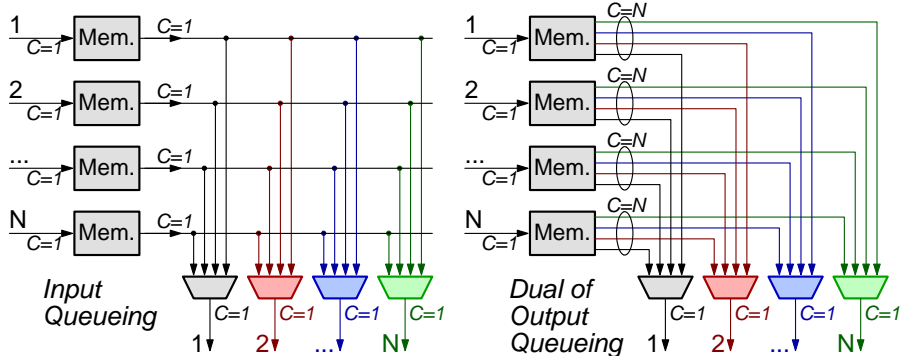

- **Asymmetry** between packet arrival and packet departure conflicts:
- Simultaneous **arrivals** may conflict with each other (packets destined to the same output), and the switch is *obliged* to accept them.
- Simultaneous **departures** are *scheduled* by the switch \Rightarrow can be made to *not* originate from the same input – albeit at potential performance cost.

4.1 - U. Crete - M. Katevenis - CS-534

8

Single Queue per Input \Rightarrow Head-of-Line (HOL) Blocking

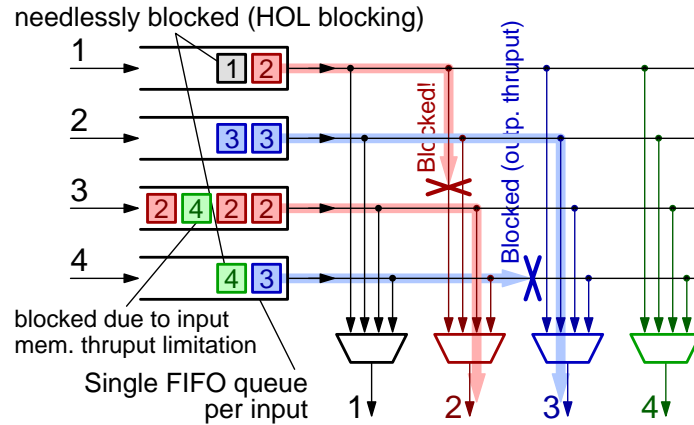

- Whenever one First-in-First-Out (FIFO) queue feeds multiple destinations, beware of the danger of head-of-line (HOL) blocking (called HOL-blocking when bottleneck is the FIFO organization – *not* when other bottleneck, e.g. memory read throughput or output port throughput)

4.1 - U. Crete - M. Katevenis - CS-534

9

Independent Per-Output Schedulers

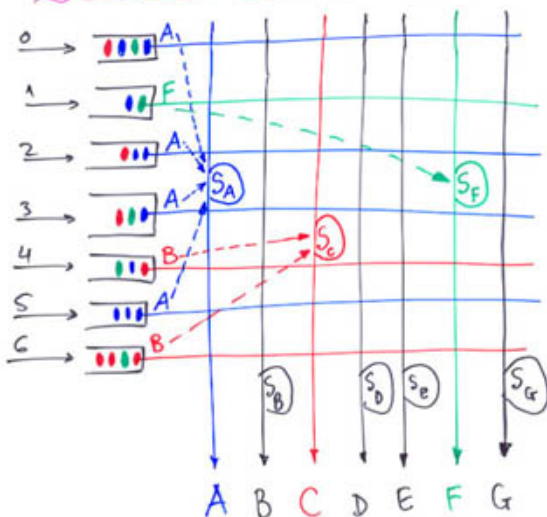

- with old-fashioned input Q.
- (as with crosspoint queuing (similar to output Q or shared buffer)).

- each output has its own scheduler
- each scheduler sees a distinct set of requests
- each scheduler independently makes a decision
- no better decision is possible by considering the other schedulers' decisions.

... unlike the next scheme (adv. inp. buffering - VQ's)....

4.1 - U. Crete - M. Katevenis - CS-534

10

Throughput & Delay under Single-Queue Input Q'ing

- References:

- M. Hluchyj, M. Karol: "Queueing in High-Performance Packet Switching", IEEE Journal on Sel. Areas in Commun. (JSAC), Dec. 1988, pp. 1587-1597.
- M. Karol, M. Hluchyj, S. Morgan: "Input versus Output Queueing on a Space-Division Packet Switch", IEEE Tr. on Commun., Dec. 1987, pp. 1347-1356.
- J. Hui, E. Arthurs: "A Broadband Packet Switch for Integrated Transport", IEEE Journal on Sel. Areas in Commun. (JSAC), Oct. 1987, pp. 1264-1273.

- *Attention:* results for i.i.d. Bernoulli (non-bursty) arrivals, with uniformly distributed destinations (no overloaded hot-spots), are only useful for gaining a rough, first insight into the behavior of systems, but are often not representative of the real behavior of systems under real traffic!...

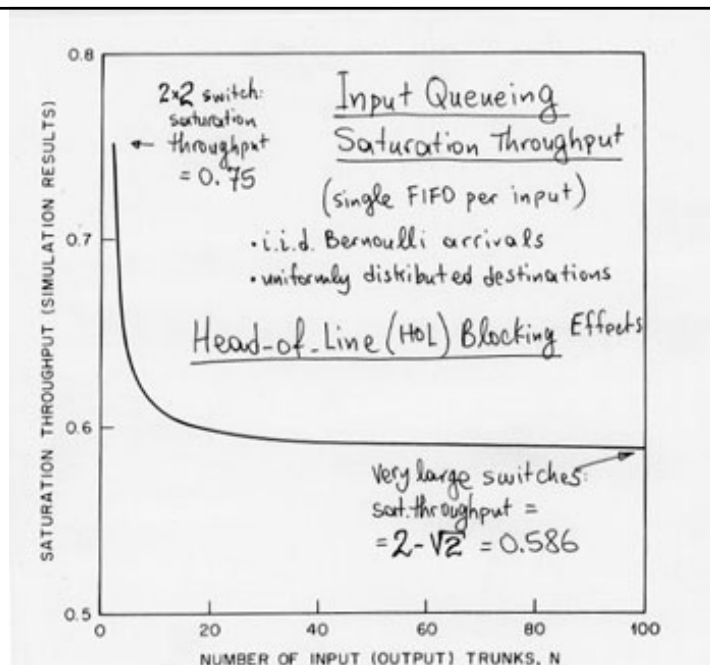

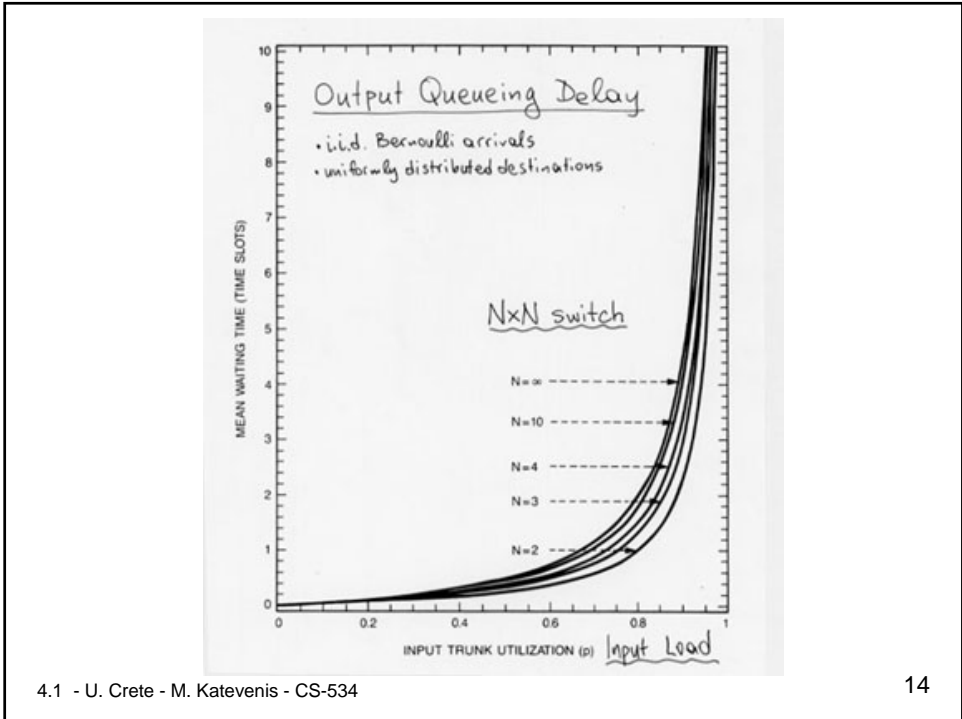
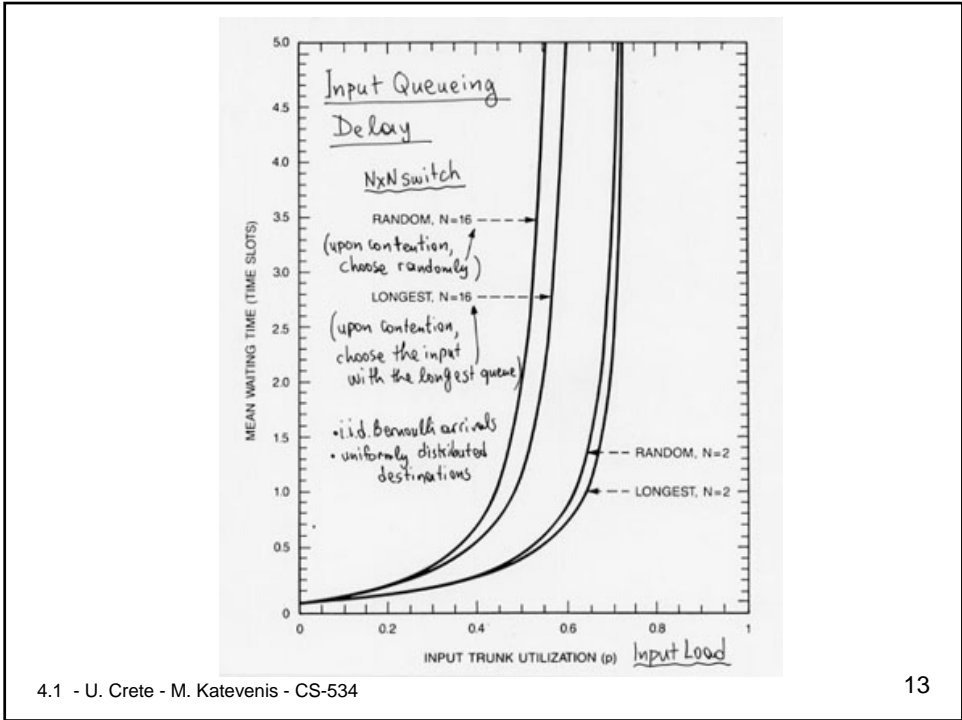

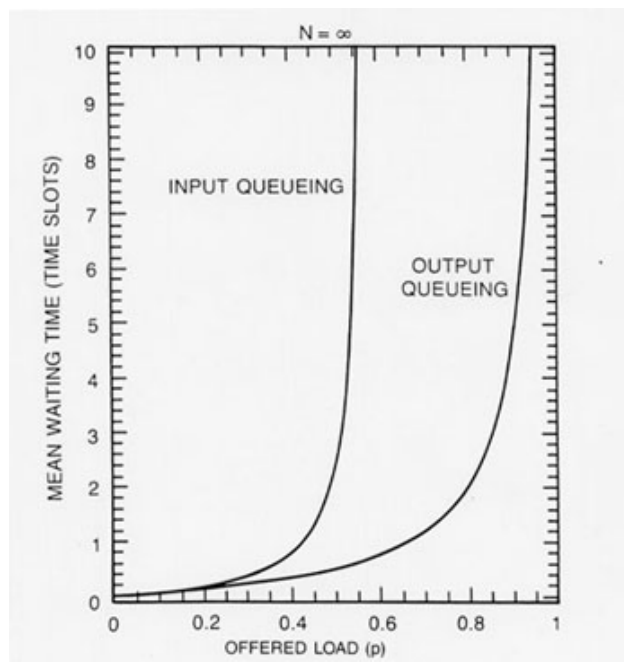

4.1 - U. Crete - M. Katevenis - CS-534

15