

HY425 Lecture 16: Shared-Memory Multiprocessors

Dimitrios S. Nikolopoulos

University of Crete and FORTH-ICS

December 5, 2011

Dimitrios S. Nikolopoulos

Motivation
Multiprocessors
Challenges
Bus-based shared-memory multiprocessors

HY425 Lecture 16: Shared-Memory Multiprocessors 1 / 36

Why do we need multiprocessors?

Uniprocessor performance

- ▶ 25% annual improvement rate from 1978 to 1986
- ▶ 52% annual improvement rate from 1986 to 2002
 - ▶ Profound impact of RISC, x86
- ▶ 20% annual improvement rate from 2002 to present
 - ▶ Power wall: solutions for higher ILP are power-inefficient
 - ▶ ILP wall: hard to exploit more ILP
 - ▶ Memory wall: ever-increasing memory latency relative to processor speed

Has this been attempted before?

Flashback in the 70s

- ▶ In the 70s, many thought that uniprocessors will reach their limits, so replicating processors would be the only way to achieve higher performance
- ▶ Predictions proved wrong because of Moore's law, architecture innovation (RISC), and inability to build, program, and maintain easily scalable multiprocessors (too expensive, too hard to program, too slow to build)
- ▶ **What has changed now?**

Parallelism at the chip-level

Vendor-Year	AMD (05)	Intel (06)	IBM (04)	Sun (05)	NVIDIA (07)
Processors/chip	2	2	2	8	128+
Threads/processor	1	2	2	4	2+
Threads/chip	2	4	4	32	768 (active) 2 billion+ (resident)

Technology trends

- ▶ Power-capped processor design motivates use of parallelism for performance
- ▶ Design by replication: leverage one design many times

Parallelism in applications

Data parallelism

- ▶ Databases, file servers
- ▶ Graphics, games
- ▶ Scientific computing
- ▶ **More recently: clients, browsers**

Request-level parallelism

- ▶ Servers, planetary-scale services

Flynn's Taxonomy

Classification based on data and control streams

- ▶ Jason Flynn, Very High-Speed Computers, *Proceedings of the IEEE*, Vol. 54, pp. 1900–1909, Dec. 1966
- ▶ **SISD: Single-instruction, single-data**
- ▶ **MISD: Multiple-instruction, single-data** (impractical)
- ▶ **SIMD: Single-instruction, multiple-data**
 - ▶ Data-level parallelism, vector instructions
 - ▶ Variation: **SIMT**, Single-instruction, multiple-threads enables divergence in instructions via conditionals (NVIDIA GPUs)
- ▶ **MIMD: Multiple-instruction, multiple-data**
 - ▶ Most common form of multi-processing
 - ▶ Flexible (used via multi-programming, or multi-threading)

Definitions

- ▶ A multiprocessor is a **collection of processing elements** that co-operate to **solve a single problem faster**.
- ▶ Multiprocessor architecture includes **processor architecture** and **communication architecture**
- ▶ Modern multiprocessors are **layered architectures** :
 - ▶ Multiple cores per chip
 - ▶ Multiple chips per board
 - ▶ Network-on-chip, network-on-board
- ▶ Scalable topologies (clusters) built with basic building blocks (cores, processors, networks).

Memory-centric classification of multiprocessors

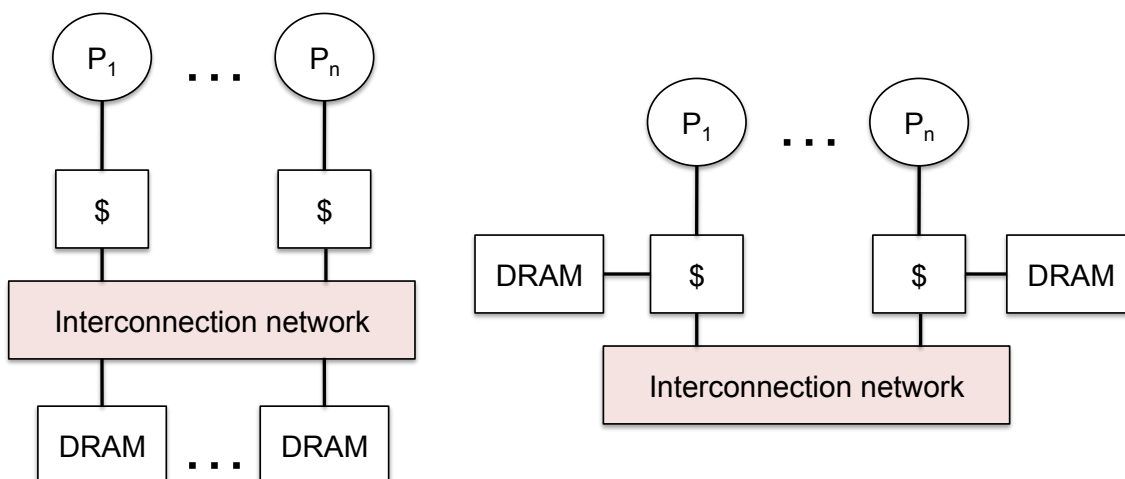

- ▶ Though hardware classification based on **physical** placement of memory relative to processors, multiprocessors are classified also based on the **abstraction** of memory provided to users. Abstraction of memory is typically decoupled from the actual implementation.

Shared memory multiprocessors

- ▶ Processors share single memory address space
- ▶ Memory address space can be implemented over **single centralized memory** or **physically distributed memory**
- ▶ Centralized memory systems are usually scalable only to few (e.g. tens) processors or cores per processor
 - ▶ Shared-memory multiprocessors based on a bus interconnect are limited by bus bandwidth (late 80's, early 90's)
 - ▶ Bus-based multiprocessors are still low-cost commodity component (8-way multiprocessor available at €1,500)
 - ▶ Concept of symmetric memory still alive: modern multi-cores have large caches, each shared between few cores for fast communication

Distributed memory multiprocessors

- ▶ Cost-effective scaling of memory bandwidth via distribution of memory between processors (or cores)
- ▶ Dependent on **effective data distribution** so that **local memory accesses are maximized**
- ▶ Local accesses cheap, **remote accesses expensive**, due to the need for **explicit communication** between processors
 - ▶ Communication delay includes delays of software (communication libraries, operating system, application overhead for preparing messages), memory, network interfaces (at communication endpoints)

Classification based on communication medium

- ▶ **Message-passing multiprocessors:** Communication occurs by explicitly passing messages between processors
- ▶ **Remote DMA multiprocessors:** Communication occurs by explicitly reading or writing data from remote memories belonging to other processors. Data replication/migration does not imply coherence or consistency
- ▶ **Shared-memory multiprocessors:** Communication occurs through loads and stores to shared memory. Processors need to synchronize (e.g. via locks and barriers) to avoid lost updates, or violation of dependencies.
 - ▶ **UMA:** Uniform memory access time, typically through shared bus.
 - ▶ **NUMA:** Non-uniform memory access time, physically distributed coherent memories, accessed via local or remote load-stores

Amdahl's Law

- ▶ What percentage of program execution time is inherently sequential?
- ▶ What is the maximum speedup if the following fractions of program execution time are sequential?
 1. 10%
 2. 5%
 3. 1%

$$Speedup_{overall} = \frac{1}{(1 - fraction_{enhanced}) + \frac{fraction_{parallel}}{Speedup_{parallel}}}$$

Memory latency

- ▶ Processor speed improving at a rate of 50% per year (20% in last 4 years), memory latency improving at a rate of 7% per year.
- ▶ Local memory access latencies of 60 ns versus remote memory access latency of over 100 ns
- ▶ Data placement important for avoiding remote memory accesses
 - ▶ Complicates parallel programming
 - ▶ Contradicts assumption of flat shared address space

Example

- ▶ Impact of remote memory accesses
- ▶ Assumptions:
 - ▶ 0.2% remote memory access rate
 - ▶ Base CPI = 0.5 (e.g. superscalar)
 - ▶ 200ns remote memory access latency

$$CPI = \text{Base CPI} + \text{Remote Request Rate} \times \text{Remote Request Cost}$$

$$CPI = 0.5 + 0.2\% \times 200 = 0.9$$

Remote memory accesses almost halve performance

The role of software in parallelism

Algorithms

- ▶ Sequential algorithms may include parallel components
- ▶ New algorithms that provide more parallelism, better scalability, lower communication/synchronization costs etc. may be needed
- ▶ Example: FFT straightforward parallelization versus Cooley-Tuckey algorithm.

The role of software in parallelism

Languages, compiler, runtime systems

- ▶ Language constructs and runtime libraries are used for communication, synchronization, data distribution, in parallel programs.
- ▶ Performance and scalability depend on the efficiency of the language/library mechanisms that implement parallelism
 - ▶ How fast can processor A provide processor B with work to do?
 - ▶ How fast can I send data from the memory of processor A to the memory of processor B?
 - ▶ How fast can I coordinate processors to provide mutual exclusion or implement a global barrier?

Shared-memory multiprocessor architecture

History

- ▶ Multiple processor on a single board, communicating over a shared bus, using loads/stores and a cache coherence protocol (80's–90's)
- ▶ Multiple processors on multiple boards in a single cabinet, communicating over a shared bus (on-board) and a scalable switch-based interconnection network (late 90's)
- ▶ Multiple processors on a single chip, communicating over a shared bus (2004–onwards) or a scalable switch-based interconnection network (2008–onwards)

Shared-memory multiprocessor architecture

Technology trends

- ▶ Bus is a centralized bottleneck and its BW is not adequate to support more than a few (e.g. 10) processors).
Replaced by switch-based interconnect
- ▶ Cache coherence desirable due to **programmability**
 - ▶ Processors communicate through loads and stores, with a model which is more familiar to sequential programmers.
 - ▶ Communication between producers and consumers done by producer storing data in local cache and consumer requesting data from remote cache
 - ▶ Coherence protocol maintains consistency between replicas of data potentially written by one or more processors.

Cache coherence

Shared data

- ▶ Private cache per processor (or processor core) on SMPs
- ▶ Cache stores both
 - ▶ **Private data** used only by **owner** processor
 - ▶ **Shared data** accessed by multiple processors
- ▶ Caches reduce latency to access shared data, memory bandwidth consumption, interconnect bandwidth consumption
- ▶ **Cache coherence problem**

Cache coherence problem

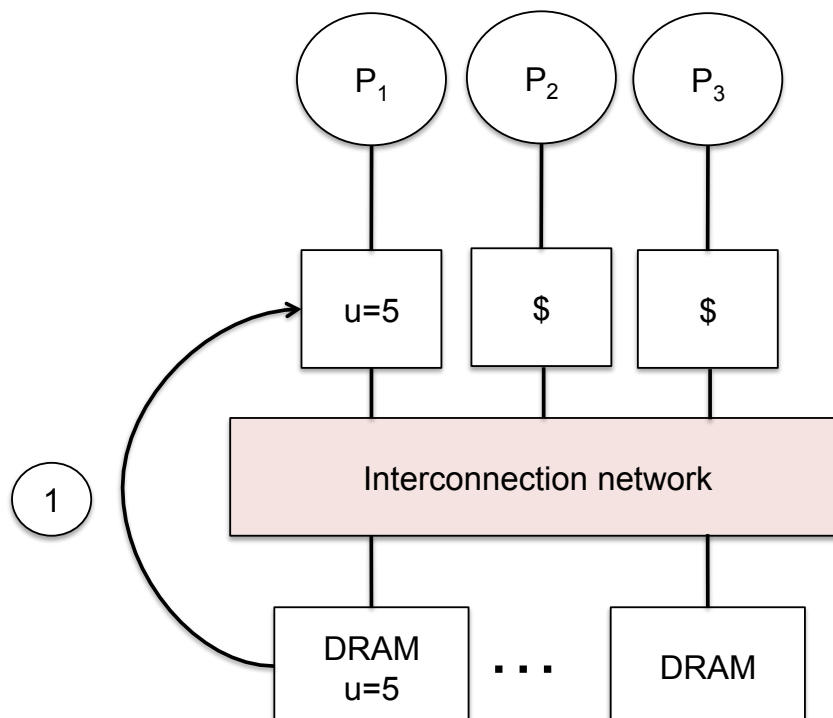

Cache coherence problem

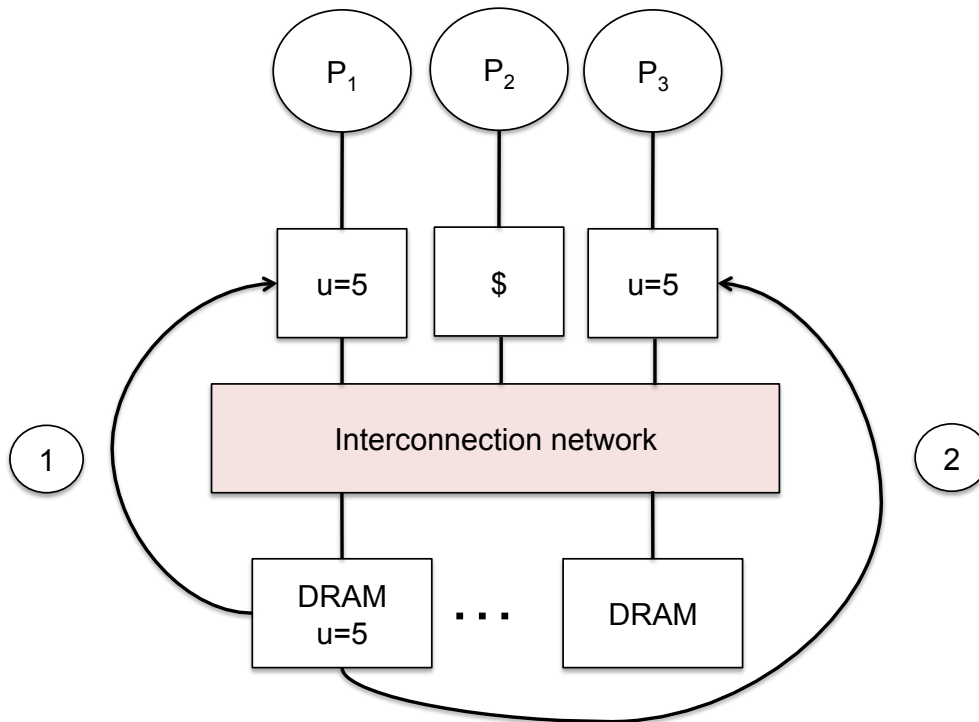

Cache coherence problem

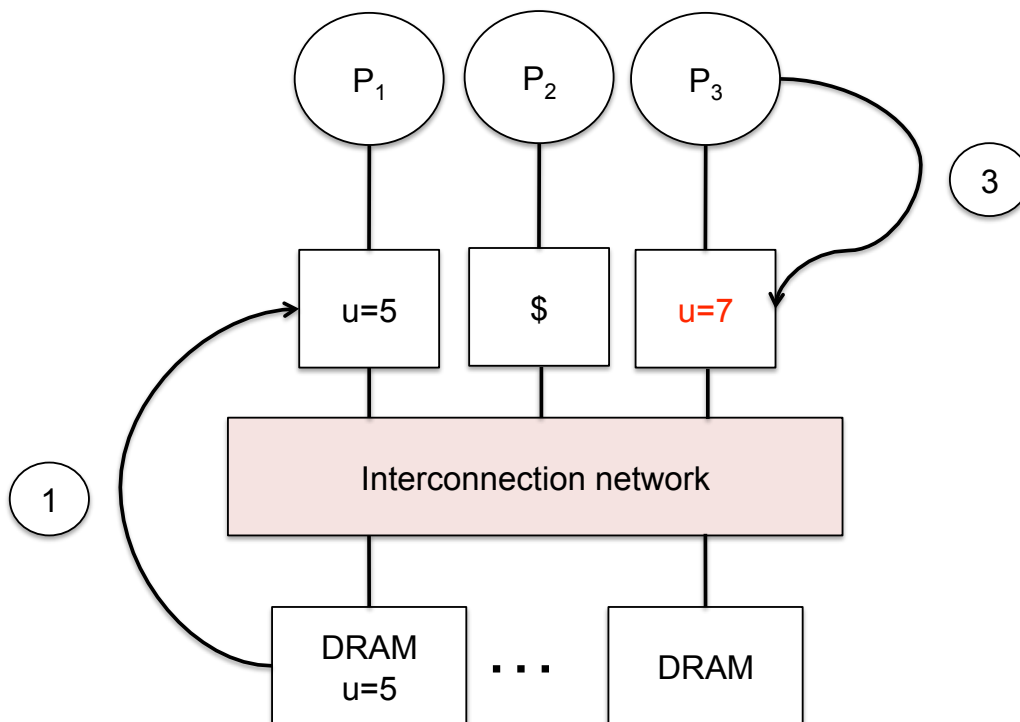

Processor 3 writes new value of u . Processor 1 and processor

Cache coherence problem

P_1	P_2
Assume initial values $A=0$, $flag=0$	
$A = 1;$	<code>while (flag==0); /* busy-wait */</code>
$flag = 1;$	<code>print A;</code>

P_1 expects that $A=1$ after exiting the while. **Intuition not guaranteed by coherence.** If memory writes from P_0 commit in order then intuition is verified. If not, then P_1 may see $A = 0$! The memory system is typically expected to preserve ordering of memory accesses by a **single processor** but **not across processors**.

Coherence versus consistency

What is the value of a memory location?

- ▶ Every **read** of a memory location should return **the last value written** to the memory location
 - ▶ In uniprocessors this is easy to implement and guaranteed except from when the processor performs I/O (DMAs)
- ▶ **Coherence** defines the values returned by a read
- ▶ **Consistency** defines when a write from a processor becomes visible to other processors
- ▶ Coherence defines the behavior of **a single processor** while consistency defines the behavior **across processors**

Coherent memory system

Preserving program order

A read by processor P to location X that follows a write by P to X, with no writes to X made by other processors between the write and the read by P will always return the value written by P.

Coherent view of memory

A read by a processor to location X that follows a write by **another processor** to X, returns the value of the write of **the two accesses are separated sufficiently apart in time and no other writes to X occur between the two accesses.**

Coherent memory system

Write serialization

2 writes to the same location by any 2 processors are **seen in the same order by all processors**

- ▶ Assume that writes are not serialized: Two processors may proceed assuming **different last values of the same location**

Write consistency

A write does not complete and does not allow the next write to occur until all processors have “seen” the effect of that write. The processor **does not change the order of any write with respect to other reads or writes**

- ▶ If a processor writes location A then location B, any processor that sees the new value of B must also see the new value of A
- ▶ **Reads can be reordered (module dependencies) but writes must happen in program order**

Schemes for enforcing coherence

- ▶ Multiple processors may have copies of same data (common in parallel programs)
- ▶ SMPs typically use a cache coherence protocol implemented in hardware, although slower software solutions are also available
- ▶ Key operations: **replication** and **migration** of data:
 - ▶ **Migration**: data can be moved to the cache of a single processor and used for **reading or writing transparently**. Reduces latency and demand for bandwidth.
 - ▶ **Replication**: Data can be simultaneously read by multiple processors, by having processors make copies of data in their local caches. Reduces latency, demand for bandwidth and contention for accessing shared data.

Classes of cache coherence protocols

- ▶ **Directory based**: Sharing status of a cache block (i.e. what processors have a copy of the block in the cache and whether this copy has been updated) is kept in one location (in memory, or on-chip in recent multi-core processors) called **the directory**
- ▶ **Snooping**: Every cache with a copy of a block also has information on the sharing status of the block, but no centralized state is kept.
 - ▶ All caches are accessible via a centralized **broadcasting mechanism** (typically a bus, nowadays a switch).
 - ▶ All cache controllers **monitor (or snoop)** the centralized medium to determine whether they have or not a copy of the block requested by another processor, and update sharing state.

Snoopy cache coherence

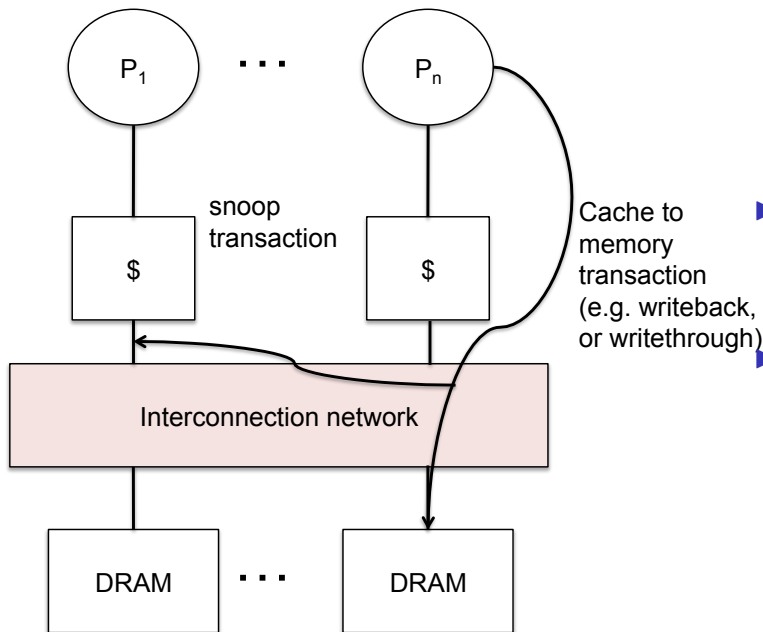

- ▶ Cache controller snoops all transactions on the shared interconnect.
- ▶ A transaction is **relevant** if it involves a block **stored in the cache of the snooping processor**.

Snoopy cache coherence

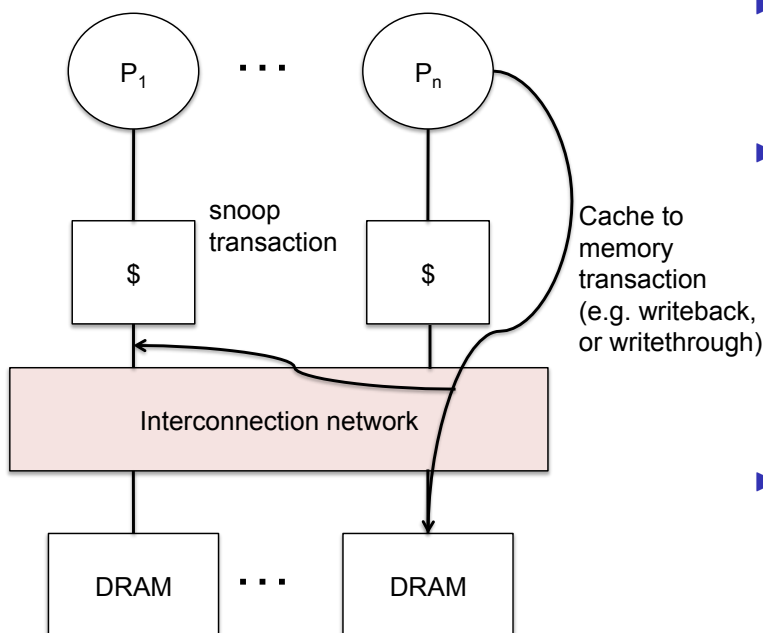

- ▶ If transaction is on relevant block, controller takes action to ensure coherence.
- ▶ Action may be **invalidate** (block written by other processor), **update** (block written by another processor and new value stored in the cache of the snooping processor), or **supply new value** (requested by other processor).
- ▶ Processor that needs to write either gets **exclusive** access to block by **invalidating other copies**, or **writes and updates other copies**.

Example: write-through, write-invalidate

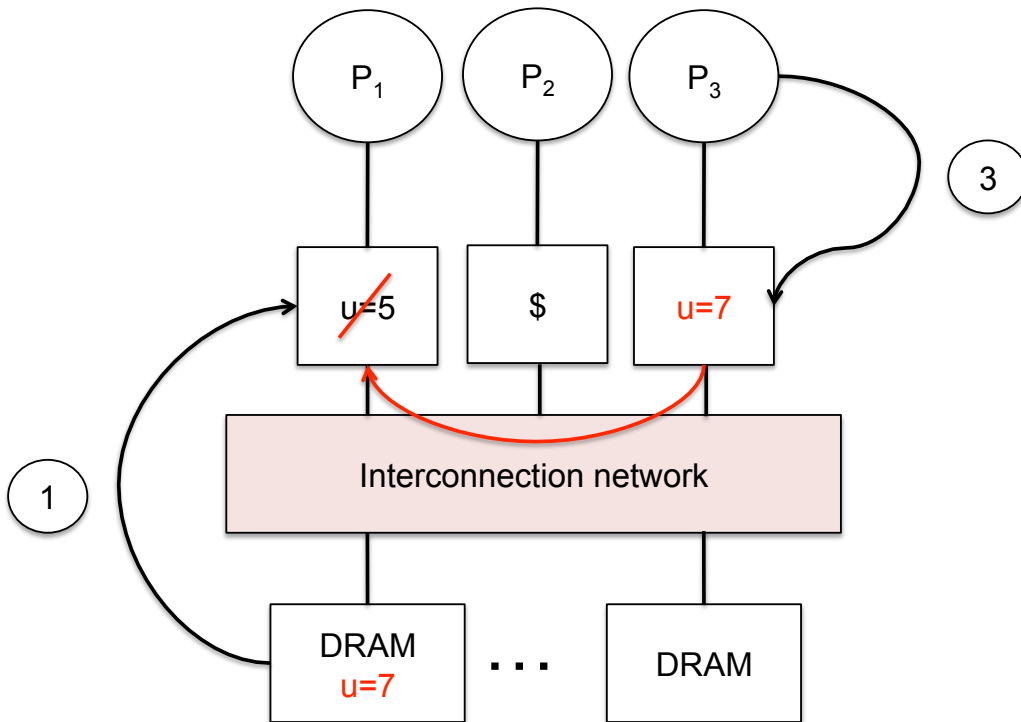

Example: write-through, write-update

