

# **HY425 Lecture 14: Improving Cache Performance II**

Dimitrios S. Nikolopoulos

University of Crete and FORTH-ICS

November 30, 2011

# Parallelism

## Overlapping memory latency with instructions

- ▶ Allow processor to work while memory serves requests
- ▶ Overlap memory latency with other instructions
- ▶ Essential in out-of-order processors

## Hide memory latency with prefetching

- ▶ Allow processor to prefetch extra data
- ▶ If data useful and fetched in time, reduces memory latency

# Non-blocking caches

## Hit under miss

- ▶ Processor continues execution while miss pending
- ▶ Cache serves hits while miss pending
- ▶ Need check for dependence violations
  - ▶ Logic for memory RAW, WAW, WAR, hazards
  - ▶ Dynamic issue processor
- ▶ Can overlap multiple misses
  - ▶ Requires suitable multi-bank, pipelined memory system
- ▶ Hard to measure miss penalty due to overlap of hits and misses

# Hit under miss performance impact

Hit Under i Misses

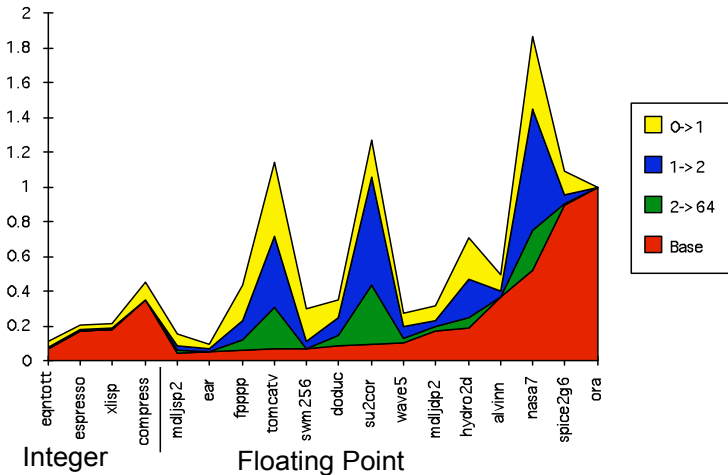

# Prefetching

## Reduce memory latency

- ▶ Processor requests data in advance
  - ▶ Processor speculates that requested data will be accessed in the future
- ▶ Need a guess for what data will be needed in the future
- ▶ Guess easy in linear memory access pattern
  - ▶ Fixed stride between data accesses
  - ▶ Strided prefetching
- ▶ Need prefetch triggers, e.g. two consecutive misses

# Prefetching

## Performance implications

- ▶ Prefetched data may **displace other useful data from cache**
- ▶ Prefetched data may **come too early and be evicted before used**
- ▶ Prefetched data may **come too late and not be there when needed**
- ▶ Prefetched data may **be useless, i.e. not accessed at all**
- ▶ Prefetched data **wastes memory bandwidth, if useless**

# Online Prefetching Heuristics

- ▶ Prefetching helps codes with non-perfect spatial locality
- ▶ Can be initiated at any level of the memory hierarchy
- ▶ Prefetched data can be stored at any level of the memory hierarchy
- ▶ Branch prediction is a form of prefetching
  - ▶ Prefetching instructions ahead of their execution
- ▶ Simple lookahead prefetching
  - ▶ Prefetch block  $i+1$  (or  $i+2$ , or  $i+3$ ,...) upon demand fetching block  $i$
  - ▶ Prefetch  $i+1$  called **next-line prefetching**

# Lookahead prefetching

- ▶ Three ways to prefetch:
  - ▶ Upon every memory access
    - ▶ Excessive memory traffic
  - ▶ Upon a cache miss
    - ▶ Catches contiguous streams of data non-present in the cache
    - ▶ Requires a miss before prefetching is initiated
  - ▶ Tagged prefetch
    - ▶ One bit per cache block indicates if block was referenced
    - ▶ Bit set to zero if block was prefetched
    - ▶ Zero-to-one transition indicates access that **would have been a miss if block were not prefetched** and triggers lookahead prefetching

# Stream Buffers

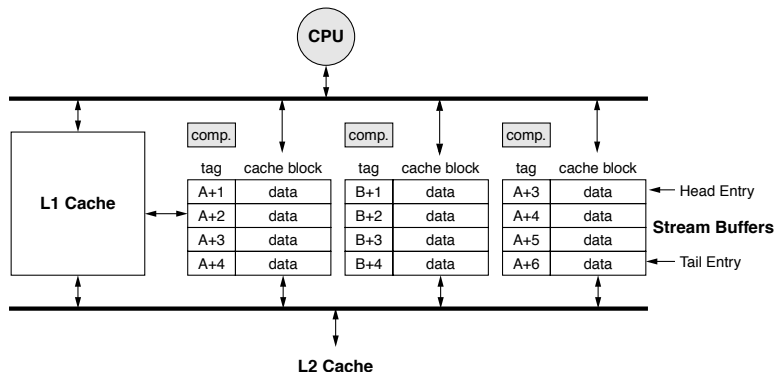

- ▶ Each buffer fetches data from one contiguous stream
- ▶ Cache and head entries of stream buffers checked upon access
- ▶ Cache miss may be served by head of stream buffer

# Stream Buffers

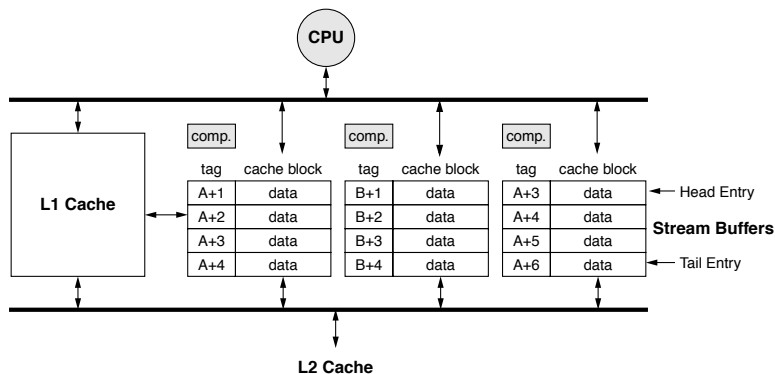

- ▶ If cache miss hits on stream buffer, head pointer moves down and prefetching is triggered
- ▶ Available bit per entry indicates if prefetching is in flight
- ▶ Buffer allocated when a stream of misses (e.g. address A, A+1,...) is detected

# Strided Prefetching Motivation

- ▶ Assume the reference pattern: A, B, A+2, B+1, A+4, B+2,...
- ▶ Stream buffer space wasted in this case

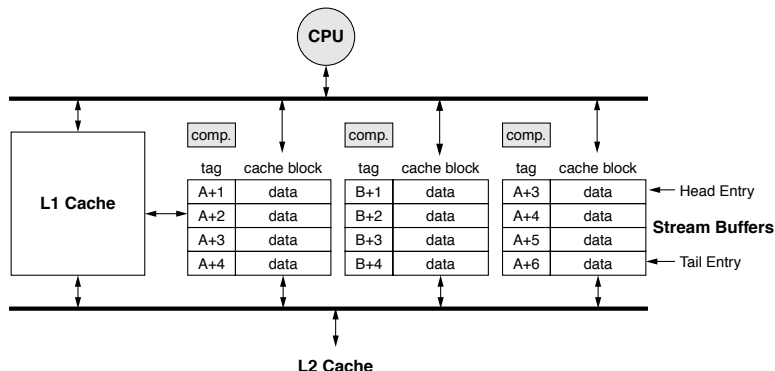

# Strided Prefetching

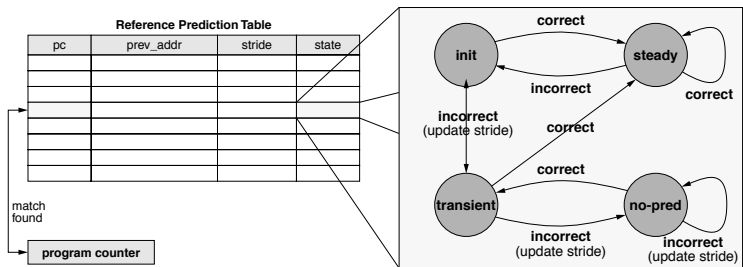

- ▶ **Reference prediction table** tracks load/store accesses and strides between addresses of the same load/store
- ▶ Stride used to make prediction of next address to prefetch
- ▶ FSM tracks and fixes stride predictions

# Strided prefetching without the Program Counter

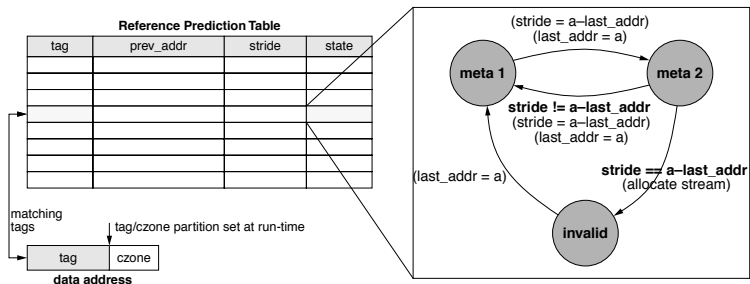

- ▶ Tag partitions the address space in regions
- ▶ Prefetcher separates streams in different address regions
- ▶ FSM requires three references that miss

## Correlation Prefetching

- ▶ Prefetching repeating patterns that are not dominated by a single or a few strides
- ▶ Algorithmic locality often not captured by strides (e.g. walking trees with dynamically allocated memory)

### Correlation Table

(i)

NumRows=4

|   |   |  |
|---|---|--|
| a | b |  |
| b | c |  |
| c |   |  |
|   |   |  |

NumSucc=2

### Miss Sequence

current miss



a,b,c,a,d,c,...

## Correlation Prefetching

- ▶ Second Snapshot
- ▶ Successors of miss stored in **MRU** order
- ▶ Hardware keeps pointer to row of last observed miss
- ▶ On miss hardware **updates successors** and **starts new correlation stream**

(ii)

|   |   |   |
|---|---|---|
| a | d | b |
| b | c |   |
| c | a |   |
| d | c |   |

current miss



a,b,c,a,d,c,...

# Correlation Prefetching

- ▶ Third Snapshot
- ▶ **Only successors** in single row prefetched, limits performance

(iii)

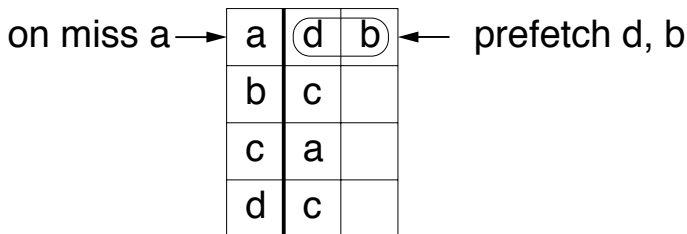

# Multi-level Correlation Prefetching

- ▶ Maintain multiple pointers (a queue) in the correlation table
- ▶ Replicate miss information in the table

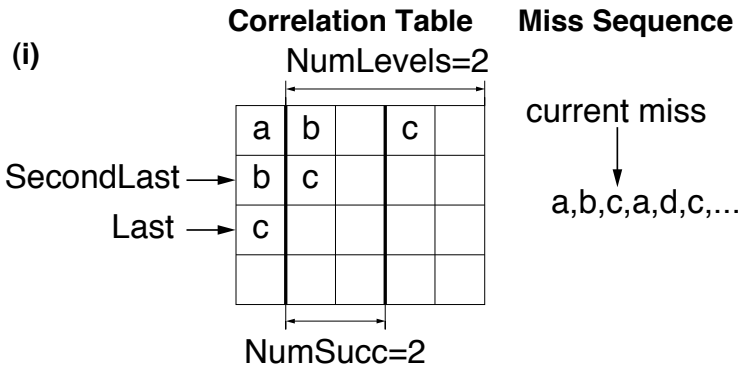

# Multi-level Correlation Prefetching

- ▶ Maintain multiple pointers (a queue) in the correlation table
- ▶ Replicate miss information in the table

(ii)

|              |   |   |   |   |  |
|--------------|---|---|---|---|--|
|              | a | d | b | c |  |
|              | b | c |   | a |  |
| Last →       | c | a |   | d |  |
| SecondLast → | d | c |   |   |  |

current miss  
 ↓  
 a,b,c,a,d,c,...

## Multi-level Correlation Prefetching

- ▶ Use NLEVELS-1 successors to index the table and prefetch more
- ▶ Example: NLEVELS=2

(iii)

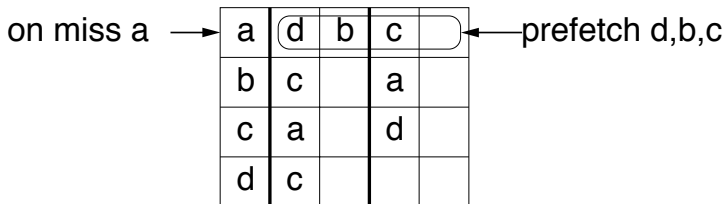

## Other Prefetching Schemes

- ▶ Content-based prefetching
  - ▶ Identify **two loads** out of which one produces the address consumed by the other
  - ▶ Indicates **pointer chasing**
- ▶ Content-directed prefetching
  - ▶ Scan words fetched from memory to **speculate if they are likely addresses**
  - ▶ Prefetch if word fetched is an address

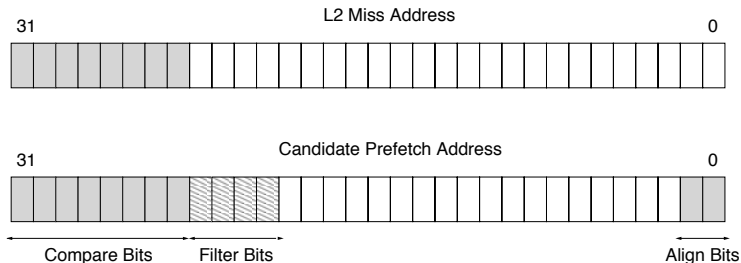

# Dynamic Data Structure Reorganization for Locality

- ▶ List linearization
- ▶ Idea borrowed from garbage collection

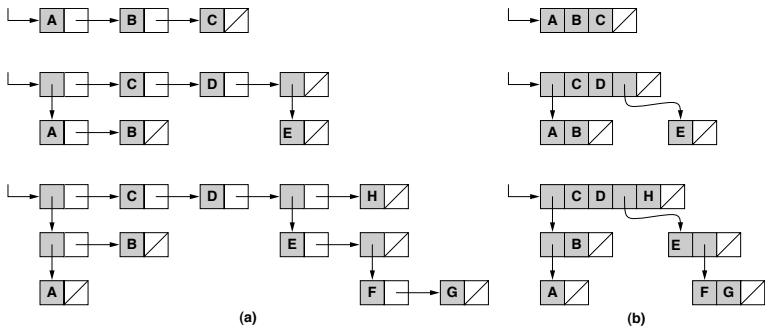

# Page Coloring

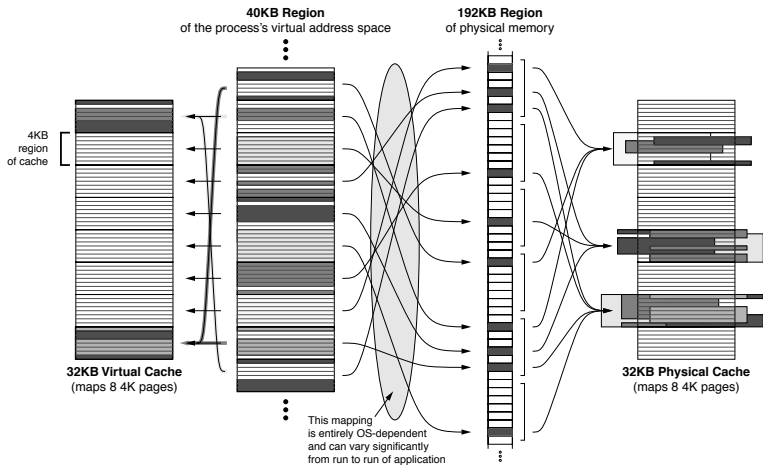

# Page Coloring

- ▶ Physical layout of pages of data in DRAM **differs** from physical layout of pages of data in cache
- ▶ Consequence of **virtual-to-physical** address translation
- ▶ Software can implement **conflict-free placement of pages** if cache is **virtually-indexed**
  - ▶ Placing working set in adjacent virtual pages guarantees mapping in adjacent cache page-size regions
- ▶ Page coloring
  - ▶ Match **bottom bits of virtual page number with bottom bits of physical frame number**
  - ▶ Implemented using **bins of physical pages** that map to the same page-size region in the cache
  - ▶ Implementation lies in the operating system

# Software Prefetching

Mowry's algorithm:

- ▶ Identify statically references that miss using **locality analysis**
- ▶ Examples assumes array elements are doubles and cache block is 32 bytes

```

a) for (j=2; j <= N-1; j++)
    for (i=2; i <= N-1; i++)
        A[j][i]=0.25*(B[j][i-1]+B[j][i+1]+B[j-1][i]+B[j+1][i]);

b) for (j=2; j <= N-1; j++) {
    for (i=2; i <= PD; i+=4) { // Prologue
        prefetch(&B[j][i]);
        prefetch(&B[j-1][i]);
        prefetch(&B[j+1][i]);
        prefetch(&A[j][i]);
    }
    for (i=2; i < N-PD-1; i+=4) { // Steady State
        prefetch(&B[j][i+PD]);
        prefetch(&B[j-1][i+PD]);
        prefetch(&B[j+1][i+PD]);
        prefetch(&A[j][i+PD]);

        A[j][i]=0.25*(B[j][i-1]+B[j][i+1]+B[j-1][i]+B[j+1][i]);
        A[j][i+1]=0.25*(B[j][i]+B[j][i+2]+B[j-1][i+1]+B[j+1][i+1]);
        A[j][i+2]=0.25*(B[j][i+1]+B[j][i+3]+B[j-1][i+2]+B[j+1][i+2]);
        A[j][i+3]=0.25*(B[j][i+2]+B[j][i+4]+B[j-1][i+3]+B[j+1][i+3]);
    }
    for (i=N-PD; i <= N-1; i++) // Epilogue
        A[j][i]=0.25*(B[j][i-1]+B[j][i+1]+B[j-1][i]+B[j+1][i]);
}

```

# Software Prefetching

Mowry's algorithm:

- ▶ Algorithm identifies **spatial reuse** (all references in example), **temporal reuse** for each reference and **temporal reuse** for group of references
- ▶ Algorithm computes **number of iterations** between reuses and **volume of data accessed** to identify misses

```

a) for (j=2; j <= N-1; j++)
    for (i=2; i <= N-1; i++)
        A[j][i]=0.25*(B[j][i-1]+B[j][i+1]+B[j-1][i]+B[j+1][i]);

b) for (j=2; j <= N-1; j++) {
    for (i=2; i <= PD; i+=4) { // Prologue
        prefetch(&B[j][i]);
        prefetch(&B[j-1][i]);
        prefetch(&B[j+1][i]);
        prefetch(&A[j][i]);
    }
    for (i=2; i < N-PD-1; i+=4) { // Steady State
        prefetch(&B[j][i+PD]);
        prefetch(&B[j-1][i+PD]);
        prefetch(&B[j+1][i+PD]);
        prefetch(&A[j][i+PD]);

        A[j][i]=0.25*(B[j][i-1]+B[j][i+1]+B[j-1][i]+B[j+1][i]);
        A[j][i+1]=0.25*(B[j][i]+B[j][i+2]+B[j-1][i+1]+B[j+1][i+1]);
        A[j][i+2]=0.25*(B[j][i+1]+B[j][i+3]+B[j-1][i+2]+B[j+1][i+2]);
        A[j][i+3]=0.25*(B[j][i+2]+B[j][i+4]+B[j-1][i+3]+B[j+1][i+3]);
    }
    for (i=N-PD; i <= N-1; i++) // Epilogue
        A[j][i]=0.25*(B[j][i-1]+B[j][i+1]+B[j-1][i]+B[j+1][i]);
}

```

# Software Prefetching

Mowry's algorithm:

- ▶ Loop unrolling and peeling **isolate cache misses** (one per reference per unrolled iteration in example)
- ▶ Compiler inserts prefetches for references that miss using a **prefetch distance**, measured in **iterations**

```

a) for (j=2; j <= N-1; j++)
    for (i=2; i <= N-1; i++)
        A[j][i]=0.25*(B[j][i-1]+B[j][i+1]+B[j-1][i]+B[j+1][i]);

b) for (j=2; j <= N-1; j++) {
    for (i=2; i <= PD; i+=4) { // Prologue
        prefetch(&B[j][i]);
        prefetch(&B[j-1][i]);
        prefetch(&B[j+1][i]);
        prefetch(&A[j][i]);
    }
    for (i=2; i < N-PD-1; i+=4) { // Steady State
        prefetch(&B[j][i+PD]);
        prefetch(&B[j-1][i+PD]);
        prefetch(&B[j+1][i+PD]);
        prefetch(&A[j][i+PD]);

        A[j][i]=0.25*(B[j][i-1]+B[j][i+1]+B[j-1][i]+B[j+1][i]);
        A[j][i+1]=0.25*(B[j][i]+B[j][i+2]+B[j-1][i+1]+B[j+1][i+1]);
        A[j][i+2]=0.25*(B[j][i+1]+B[j][i+3]+B[j-1][i+2]+B[j+1][i+2]);
        A[j][i+3]=0.25*(B[j][i+2]+B[j][i+4]+B[j-1][i+3]+B[j+1][i+3]);
    }
    for (i=N-PD; i <= N-1; i++) // Epilogue
        A[j][i]=0.25*(B[j][i-1]+B[j][i+1]+B[j-1][i]+B[j+1][i]);
}

```

# Pointer Prefetching

## Pointer chasing:

a) 

```
struct node {data, next}
    *ptr, *list_head;
```

```
ptr = list_head;
while (ptr) {
    prefetch(ptr->next);
    ...
    ptr = ptr->next;
}
```

b) 

```
struct node {data, left, right}
    *ptr;
```

```
void recurse(ptr){
    prefetch(ptr->left);
    prefetch(ptr->right);
    ...
    recurse(ptr->left);
    recurse(ptr->right);
}
```

# Pointer Prefetching

## Prefetching using jump pointers:

- a) `struct node {data, next, jump}`  
`*ptr, *list_head, *prefetch_array[PD], *history[PD];`  
`int i, head, tail;`
- ```

for (i = 0; i < PD; i++) // Prologue Loop
    prefetch(prefetch_array[i]);

ptr = list_head;
while (ptr->next) { // Steady State Loop
    prefetch(ptr->jump);
    ...
    ptr = ptr->next;
}

```
- b) `for (i = 0; i < PD; i++) history[i] = NULL;`  
`tail = 0;`  
`head = PD-1;`
- ```

ptr = list_head;
while (ptr) { // Prefetch Pointer Generation Loop
    history[head] = ptr;
    if (!history[tail])
        prefetch_array[tail] = ptr;
    else
        history[tail]->jump = ptr;
    head = (head+1)%PD;
    tail = (tail+1)%PD;
    ptr = ptr->next;
}

```